

*THE DAB-300 SERIES DUAL PATH IBOC SWITCHER
SYNCHRONOUS SWITCHING OF ANALOG & DIGITAL PATHS
SIMULTANEOUSLY*



The DAB-300 is an analog and digital switcher

The new DAB-300 Series switcher is ideal for digital audio IBOC routing. Allows simultaneous synchronous switching of both analog & digital paths, and provides a low cost solution to your digital and/or analog audio routing and switching needs. Available in combinations of AES, Analog L/R and composite baseband input. Can be ordered with any two input standards. DSP Architecture provides outstanding flexibility and reliability in a single rack chassis. The DAB-300 incorporates a high quality silence detector for efficient, error free switching upon loss of analog or digital transmitter path audio. **Digital broadcasting requires synchronized audio paths and switching. The DAB-300 is designed to provide time aligned switching of both paths simultaneously automatically or manually.**

Analog Stereo Pairs AES Digital Stereo Pairs Configuration Chart

Model	IN 1-4	IN 5-8	OUT 1-4	OUT 5-8
DAB-300-1	AES	AES	AES	AES
DAB-300-2	AES	ANALOG	AES	ANALOG
DAB-300-3	AES	ANALOG	AES	AES
DAB-300-4	AES	COMP	AES	COMP
DAB-300-5	AES	COMP	AES	AES
DAB-300-6	AES	COMP	AES	ANALOG

The DAB is intended for any application where high quality, synchronous AES or hybrid AES/analog switching is required. Every digital input can accept from 8-96 KHz sample rates and are frame rate converted to 44.1 or 48KHz output sample rate which is user configurable. Call or email us today with your requirements as this flexible system can be customized to meet your exacting requirements.



Broadcast Devices, Inc.

Tel. (914) 737-5032 Fax.. (914) 736-6916

Visit us on the web at: www.Broadcast-Devices.com

Technical Specifications

Digital	
Inputs:	AES3 Balanced 110 Ohm Impedance
Sample Rates:	8 - 96 KHz
Outputs:	AES3 Balanced 110 Ohm Impedance
Sample Rates:	8 - 48 KHz 24 bits throughout with sample rate conversion on all digital inputs
Connector Style:	DB-25 I/O - Compatible with Standard DB-25 to XLR Breakout Cables or Panels Available from BDI
Remote Control:	GPIO Interface momentary closure to ground or Serial/USB for manual channel selection, remote enable/disable, alarm reset
Status:	Open Collector GPIO or Serial/USB Interface
Analog L/R	
Inputs:	Balanced +4/-10 dBm nominal - selectable gain adjust +/- 10 dB in 1 dB inc.
Outputs:	Balanced -10 dBFS analog equivalent - 4 or 8 depending on model
Frequency Response:	+/- 0.25 dB from 20 Hertz to 20 KHz
Composite Baseband	
Inputs:	4 - Balanced or unbalanced - 53 KHz LPF -3 dB point 57 KHz
Outputs:	4 - Unbalanced of selected input through distribution amplifier
De emphasis:	1 - 4 AES3 converted output - DSP based stereo decoder/AES Encoder 75/50uS or none
General	
Power Requirements	100 - 240 VAC 50 - 60 Hertz
Physical	19" W X 1.75" H X 10" D EIA Rack Standard
Environmental:	0-60 Degrees C Non Condensing Atmosphere

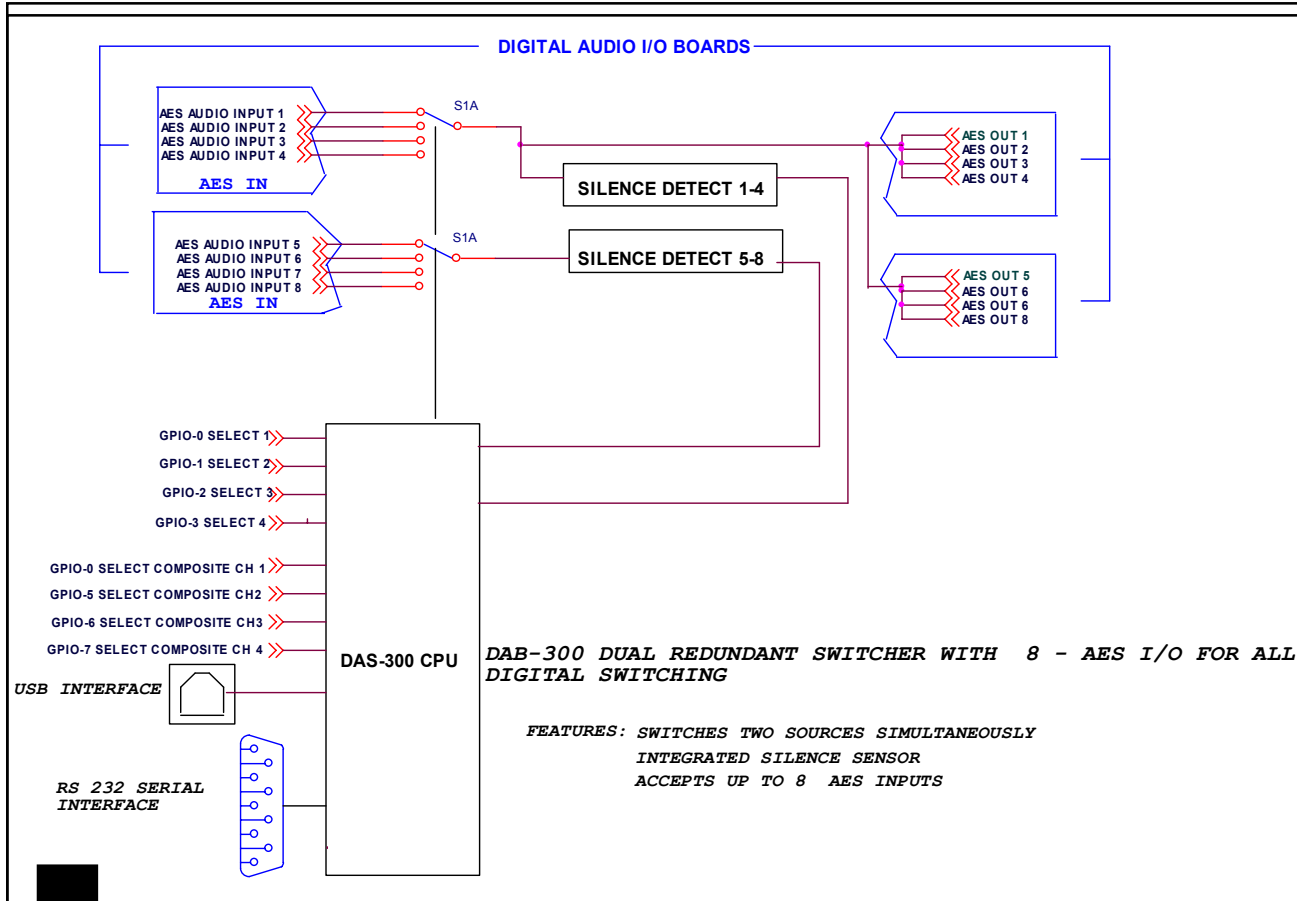

Simplified diagram of "all digital" I/O models

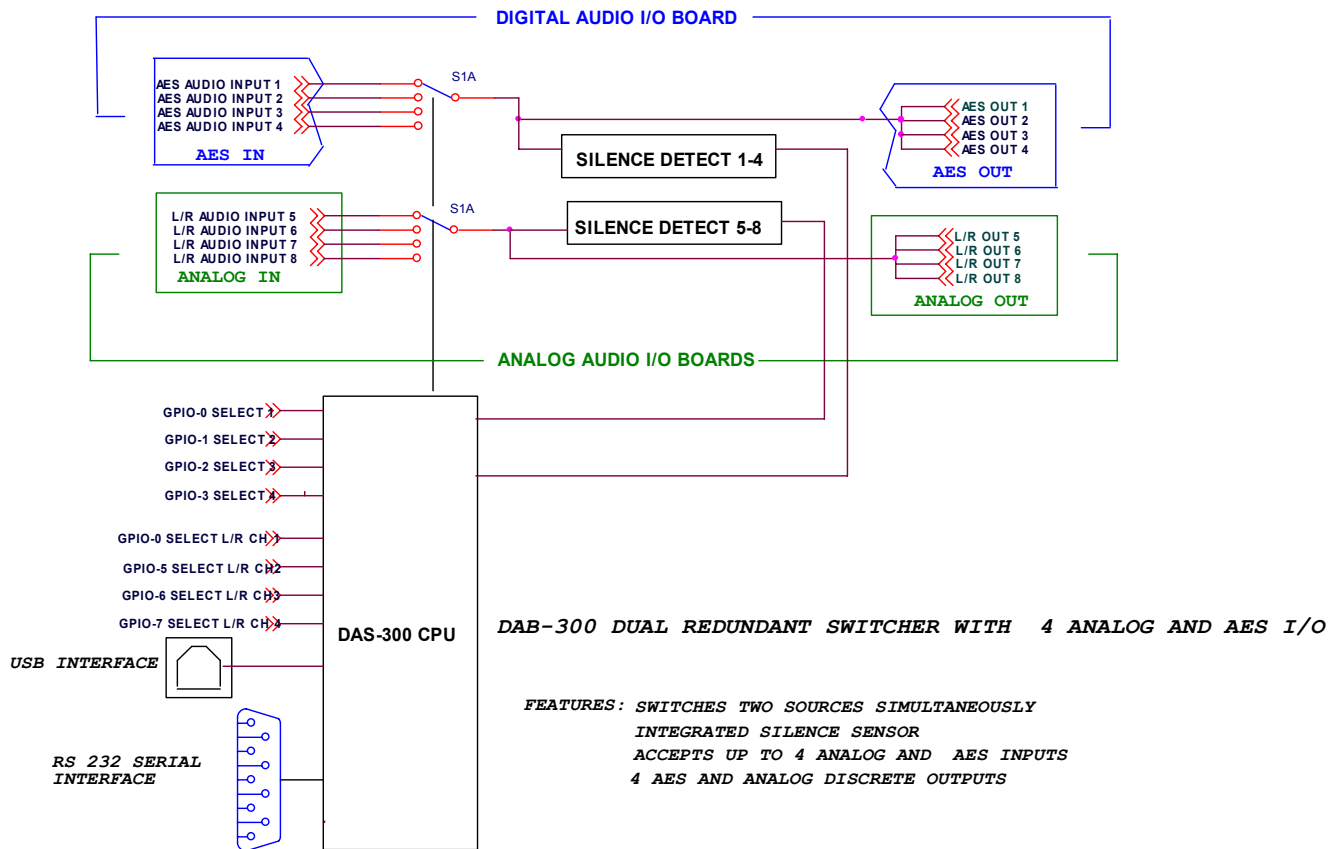

Simplified diagram of hybrid “digital/analog” I/O models

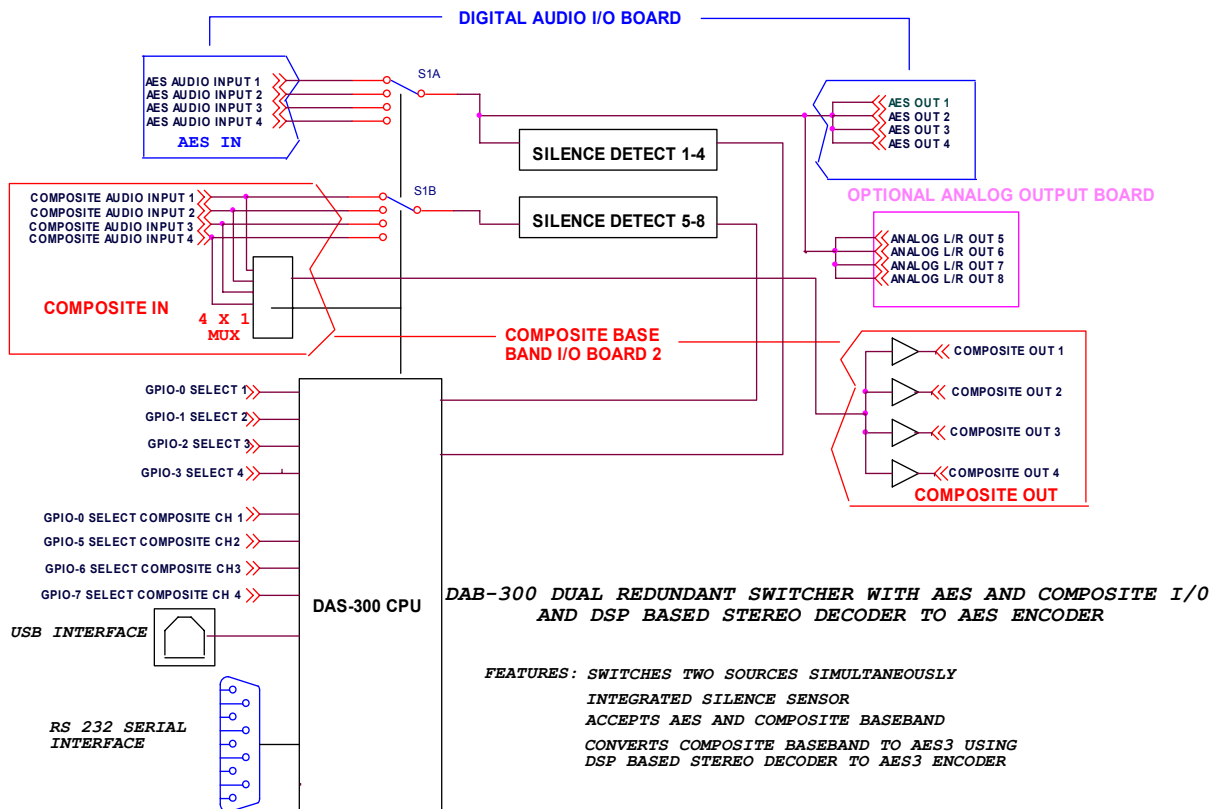

Simplified diagram of hybrid “digital/composite base-band” I/O models