



Broadcast Devices, Inc.

***GPM-300 General Purpose Audio Matrix
*Digital/Analog Audio Switcher***

Operations Quick Start Guide

**Broadcast Devices, Inc.
2066 E. Main Street
Cortlandt Manor, NY 10567**

**Tel. (914) 737-5032
Fax. (914) 736-6916
World Wide Web: www.Broadcast-Devices.com**

**Firmware Version 2.0.26 and higher
Rev C. 04/11**

***Option Dependent**

Table of Contents

I.	Basic Description	3
II.	GPM-300 Operational Description	3-5
III.	Remote Control Operation	6
IV.	Input Mode Selection Menu System	6-9
V.	Silence Sensor Interval Programming	9-10
VI.	GPM-300 Operational Modes	10-11
VII.	GPM-300 Auxiliary Programming Functions	12-13
VIII.	Audio I/O Connector Diagrams	14-15
IX.	Remote Control Connector Diagrams	16-18
X.	GPM-300 Block Diagram	19
XII.	Frame Rate Conversion Switch Selection	20-21
XIII.	Warranty	22

I. Basic Description

The GPM-300 - can be ordered for four or eight inputs. The inputs can be AES3 digital and/or analog depending on model. Please refer to the model designation chart below.

GPM-300-1, 4 - AES I/O
GPM-300- 2, 8 – AES I/O
GPM-300- 3, 4 - AES I/O, 4 Analog Input
GPM-300- 4, 4 – AES I/O, 4 Analog I/O

The GPM-300 General Purpose Matrix Switcher system provides up to 8 inputs which can be selected to any of 8 outputs. Each input has an A and B input designation that can be programmed from the front panel described below. Individual remote control of input selection to each output is also possible. The GPM-300 allows for the switching between analog and digital signals in one complete package. The GPM-300 also incorporates an automatic mode with silence sensor if desired or can be used in the manual mode for general purpose switching applications.

II. GPM-300 - Operational Description

When power is first applied to the GPM-300 after approximately 5 seconds the unit display should be as shown below:

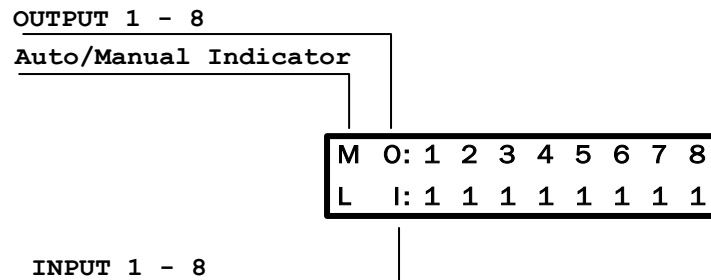

If no audio is being fed to the unit on any channel the numbers in the lower half of the display will be inverted indicating no audio present. After approximately 5 seconds of audio application on a given channel the respective lower channel indicator will become un-inverted indicating audio present above the on the channel.

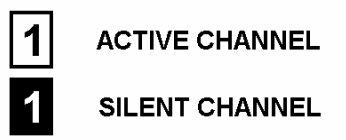

Basic 4 X4 / 8 X 8 router function can be accomplished from the front panel. Any input can be selected to any output.

To select an input to an output review this example:

Suppose it is desired to route input #3 to output #5

1. If the unit is in Auto Mode place it in manual mode by pressing the F1/F5 button once.
2. Select output #5 by moving the <> keys until the blinking cursor in the lower half of the display is under output #5.
3. Use the ^ v keys to select input #3
4. Once input #3 is selected press the Green Check Mark key to make the selection. Selection of the channel only happens after the Green Check Mark key is depressed. If not the cursor will continue to blink until the Green Check Mark key is pressed or the Red X key is pressed to cancel the selection.

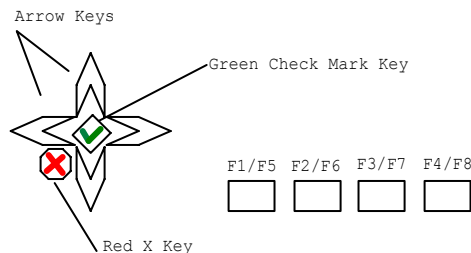
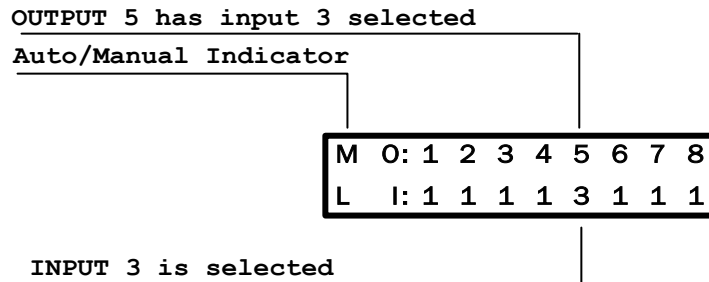

Router operation is separate from the A/B channel selection function described below. Because the GPM-300 is a versatile switcher it can be used for different applications where different functionality is required.

Configuring the “A” and “B” channels to be selected by remote inputs:

To enter the A/B CONFIG MENU push the F2/F6 key.

A/B CONFIG OUTPUT: 1
A IN: 1 B IN: 4

Pushing the <> Keys selects the OUPUT for which the user would like to view in order to change the A/B channel selections for that output.

Pushing the F2/F6 Key will alternately select the A IN or B IN for modification. The currently selected field will blink to indicate which field is to be modified.

Pushing the ^ v keys will allow the user to alter which channel will be selected by the A and B levels of the channel select input pin for that respective output.

Here is an example to illustrate how this all works. Let us assume that it is desired that for OUTPUT #3 that the user wants INPUT #2 to be the A input and INPUT # 3 to be the B input.

1. Select the A/B configuration menu by pressing F2/F6 if not already done.
2. Use the <> keys to navigate to OUTPUT #3 – Look at OUTPUT: indicator in upper Right Hand corner of display.
3. The A input indicator will indicate the present channel input selected and should be flashing. Use the ^ v keys to navigate to INPUT #2 which is desired in this example.
4. Press F2/F6 once to move the blinking cursor to the B IN: indicator. Use the ^ v keys to select the desired B input. In this example it is INPUT #3.
5. Review your settings and then exit the A/B CONFIG Menu by pressing F1/F5 once.

Once this action is performed for output #3, INPUT #2 will be selected when command A is selected from the GPIO remote for OUTPUT #3 and INPUT #3 will be selected when command A is selected remotely for OUTPUT #3.

Note: Settings are immediately stored in non-volatile memory. Be sure that settings are correct before exiting the A/B CONFIG Menu or moving to another output channel.

III. REMOTE CONTROLLED OPERATION

The GPM-300 provides remote control to select between inputs for each output and to enable/disable remote operation. Open collector status outputs are provided to indicate the currently selected input channel for each output channel. These outputs are capable of sinking up to 100ma and are rated at a maximum of 30v DC.

Remote Channel Selection:

The GPM-300 provides 8 sets of A and B channel selection inputs and 8 channel status outputs on a pair of remote control DB-25 connectors. Each output channel (1-8) is controlled via its respective A/B channel select pin (GPI 0-7) and provides a status output (GPO 0-7) which reflects whether the A or B input channel for that output is currently selected. Each of the 8 outputs has a pair of status indicators to indicate whether that channel's respective "A" or "B" channel is selected. The status outputs of the GPM-300 are pulled up to 5 VDC and go low to indicate the status is active. Refer to section VI. Remote Control connections for further connection information.

Note: A common use of the GPM-300 is as a master A/B switcher for multiple inputs. This is particularly useful for AES audio applications as a maximum of two sets of 4 AES3 inputs can be selected to their respective outputs. This application provides one button or serial control of all inputs by simply setting the input mode selections as follows:

(A)AES 1-4	(B) AES 5-8	Output
1	5	1
2	6	2
3	7	3
4	8	4
1	5	5
2	6	6
3	7	7
4	8	8

Programming the unit using the above chart allows all inputs to the AES 1-4 inputs to be "A" inputs and all inputs to the AES 5-8 inputs to be "B" inputs. To have one button control of all "A" and "B" inputs strap all A input select command lines and all B input

select command lines together. Momentary connection to common of these lines will cause all A inputs to be selected together and all B inputs to be selected together.

IV. Input Mode Selection Menu Operation

The GPM-300 inputs can be configured for mode of operation on an individual basis. Stereo, Mono Left, Mono Right, L+R and Stereo Swap can be configured from the front panel. Use mono left and mono right to fill in a missing channel. For example; choosing mono left will take a signal only input on the left channel and apply it to both channels at the output of the unit. Use L+R to create a monaural input from a stereo source.

```
INPUT MODE SELECTION
INPUT 1:    STEREO
```

To select the input mode press F4/F8 once. The display will indicate that you are in the INPUT MODE SELECTION menu as shown above. Select the input channel pair (1-8) using the ^ v keys. The <> arrow keys are then used to select between the following modes:

Stereo - Factory Default

LR Swap - L/R Channels Swapped

Mono L - L input fed to both L & R outputs

Mono R - R input fed to both L & R outputs

L + R - L & R inputs are summed and fed to both L & R outputs.

OFF – turns channel off

Here is an example to illustrate the procedure. Suppose a user decides that INPUT #4 should be L ONLY because a particular network feed is fed to only the left channel and it is desired to have the audio for this feed appear on both left and right outputs. To do this the GPM-300 Mono L function can be used to apply the left channel audio to both output channels by the following procedure:

1. Press F4 once to enter Input Mode Selection from Main Menu

```
INPUT MODE SELECTION
INPUT 1:    STEREO
```

2. Pressing the ^ v keys to select the input #4 channel to be changed:

```
INPUT MODE SELECTION
INPUT 4:    STEREO
```

2. Pressing the <> arrow buttons until MONO L is displayed as shown below:

```
INPUT MODE SELECTION
INPUT 4:    MONO L
```

3. The input mode is automatically saved when selected. To exit this menu press the F1 key to return to the main menu:

```
M 0: 1 2 3 4 5 6 7 8
L 1: 1 1 1 1 1 1 1 1
```

Phase Inversion Control

The GPM-300 allows the user to invert the phase (Tip/Ring Inversion) of any channel to correct for inadvertent phase inversion. To perform phase inversion:

1. Press F4/F8 twice Input Invert Control from Main Menu – Phase Inversion:

```
INPUT INVERT CONTROL
INPUT 1:    NORMAL
```

2. Pressing the ^ v keys allows you to select the input channel to be changed:
3. Pressing the <> keys allows selection of the following input modes:

Normal
Invert Left
Invert Right

Note: Phase inversion is Left or right but not both simultaneously.

Input Invert Control modes are automatically saved when selected. To exit this menu press the F1 key to return to the main menu.

Input/Output Gain Control

Press F4 three times to enter Input Gain Control menu – from Main Menu

```
INPUT GAIN CONTROL
INPUT 1:  0 dB
```

Pushing the ^ v keys allows you to select the input channel to be changed:
Pushing the <> keys allows you to adjust gain in one dB increments +/- 10 dB

Press F4 four times and the display will indicate Output Gain Control

```
OUTPUT GAIN CONTROL
INPUT 1:  0 dB
```

Pushing the ^ v keys allows you to select the output channel to be changed:
Pushing the <> keys allows you to adjust gain in one dB increments +/- 10 dB

Factory default for input and output gain controls is 0 dB. When factory default gains are used AES3 I/O is unity. When AES3 inputs are output to an analog channel the analog output will correspond to –10 dB below full scale AES3 input when AES3 input is nominal – 10 dB below full scale.

V. Silence Interval Programming

The GPM-300 has the ability to detect and switch upon silence from the active A or B input of each output.

```
AUDIO LOSS TIMEOUT
SECONDS = 60
```

Pressing the F3/F6 Key will allow programming the silence interval with the display as shown above. Select the desired interval using the ^ v keys. The interval can be set to any time between 10 and 600 seconds (Default = 60 seconds). Pushing the ENTER key will put this setting into non-volatile memory. Pushing the red X key will return to the original value before it was changed. NOTE: the ENTER key MUST be pushed to retain this setting after power is cycled. This allows the user to test a setting before

committing it to memory.

Note about silence interval: Customers have requested as a little as 10 seconds as a silence interval and we have therefore provided this capability in the GPM-300. Be careful in choosing a short duration silence interval because it is often the case that while many program directors believe 10 seconds is an eternity it can be just a few too many steps back to the control room for the overnight guy out for a smoke. The overnight guy will never tell you he was out of the studio for a smoke that long but the silence sensor will keep him honest! Now that we have cleared the air on this here is the procedure:

Silence Threshold Programming

OUTPUT LEVEL = 341
SILENCE LEVEL = 5

Pressing the F3/F6 Key twice from the main menu will allow programming of the silence threshold level. The upper line of the LCD indicates the level of the currently selected input for comparison purposes. The lower line indicates the current threshold below which a channel will be considered INACTIVE. The relative level can be set to any time between 1 and 100 (Default = 5 = - 40 dB below nominal input) using the ^ v keys. Pushing the ENTER Green Check Mark key will put this setting into non-volatile memory. Pushing the Red X key will return to the original value before it was changed. NOTE: the ENTER Green Check Mark key MUST be pushed to retain this setting after power is cycled. This allows the user to test a setting before committing it to memory.

VI. GPM-300 Operational Modes

GPM-300 Auto Mode

Pushing the F1/F4 key will alternate between the manual and auto modes. In auto mode the display will indicate Outputs 1-8 on the top line and the currently selected channel for each of the eight outputs and its activity status. If audio is active on the selected channel the number will appear normally. If the channel goes silent the number selected will invert to a black background indicating silence on the channel.

A	O:	1	2	3	4	5	6	7	8
L	I:	1	1	1	1	1	1	1	1

GPM-300 Auto Mode with Auto Return Feature

The GPM-300 silence sensor is an intelligent device in that it can not only detect silence

and switch to alternate channel it then has the ability to monitor the failed channel to determine audio restoration. In the auto return mode the GPM-300 can revert back to the primary channel if audio has been restored for a pre determined time interval.

By pressing the F3/F7 button three times from the main menu the display below will be indicated as shown below.

AUTO RETURN FUNCTION	
MINUTES = 1	

To adjust the auto return time use the ^ v keys to adjust in increments of minutes from 1 to 60. The factory default setting is “Auto Return Disabled”. If auto return is not desired leave the unit in the AUTO RETURN DISABLED mode.

If auto return is activated and the unit placed in the auto mode, the display will indicate a + sign next to the A in the upper left hand corner of the screen indicating that the unit is in auto mode and auto return is activated. See the display figure below.

A+	O:	1	2	3	4	5	6	7	8
L	I:	1	1	1	1	1	1	1	1

GPM-300 Auto Mode With Auto Return Function Enabled Display

GPM-300 Manual Mode

The GPM-300 can be operated in the manual mode as a routing switcher as discussed earlier or as a multiple A/B switcher. In the manual mode channel navigation and switching can be performed from the front panel, GPIO rear panel interface, and serially. The GPIO control is limited to selecting the pre programmed A/B inputs for each output. The front panel control allows 4 X 4/ 8 X 8 routing and the Serial mode is a special mode for EAS operations.

M	O:	1	2	3	4	5	6	7	8
L	I:	1	1	1	1	3	1	1	1

GPM-300 Manual Mode Display

VII. GPM-300 Auxiliary Programming Functions

GPM-300 Audible Alarm

The GPM-300 has an audible alarm feature which can be programmed from the front panel. The Audible alarm will sound after a silence detection sequence has occurred. A sonalert within the unit will sound until the unit is reset either remotely or from the front panel. This feature can be turned on or off with the following procedure:

1. Enter AUDIBLE ALARM CONFIG screen by pressing F3/F7 four times from the main screen as shown below.

AUDIBLE ALARM CONFIG
ENABLED

2. To disable the audible alarm use the v key to select "DISABLED"
3. To enable the audible alarm use the ^ key to select "ENABLED"

GPM-300 Auxiliary Alarm Relay Function and Remote Enable

The GPM-300 has two sets of form C contact relays available on the remote control enable/FLT reset connector. K1 is a maintained closure relay and K2 can be programmed to be maintained or momentary in its action. Both relays are activated by a silence alarm detection sequence. K1 is normally connected to a status input on a remote control system to indicate a fault has occurred. K2 can be used for this function in the maintained mode but can also be used as a remote start for an auxiliary audio source in case of failure of remote link audio. For example, a CD/DVD player or remote server can act as an auxiliary audio source and K2 programmed for momentary closure can be used to start such an auxiliary source connected to a GPM-300 input.

Factory default for K2 is MOMENTARY CLOSURE. To change this to MAINTAINED CLOSURE follow the procedure outlined below.

1. Enter the AUX RELAY CONFIG Menu by pressing the F3/F7 key 5 times from the main display screen as shown below

AUX RELAY CONFIG
MOMENTARY CLOSURE

2. Use the v key to change to MAINTAINED CLOSURE. The display will indicate the new relay configuration information as shown below.

AUX RELAY CONFIG MAINTAINED CLOSURE
--

3. Remote enable is displayed as shown below and is accomplished by connecting pins 8 and 21 of the rear panel FLT ST/RC EN connector.

A O: 1 2 3 4 5 6 7 8
R I: 1 2 3 4 5 6 7 8

The R in the lower left hand corner indicates that the remote is enabled. Without this connection the GPIO remote control is disabled and the R is replaced by an L to indicate local control. The RS232 remote control is always enabled regardless of this connection.

GPM-300 Factory Default Recovery

As with any programmable device, it is possible that the user would like to quickly return to the “factory default” settings. To return the GPM-300 to its factory configuration remove AC power to the unit. While holding the red “X” key, restore AC power until the display indicates “FACTORY DEFAULT”. The default condition is such that “A” and “B” inputs are 1 and 4 respectively.

M O: 1 2 3 4 5 6 7 8
L I: 1 1 1 1 1 1 1 1

Display after “FACTORY DEFAULT” reset.

A/B CONFIG OUTPUT: 1
A IN: 1 B IN: 4

Display after pressing F2/F6 after a "FACTORY DEFAULT" reset

III. Audio I/O Connections

GPM-300 Audio Connections

DIGITAL AUDIO I/O

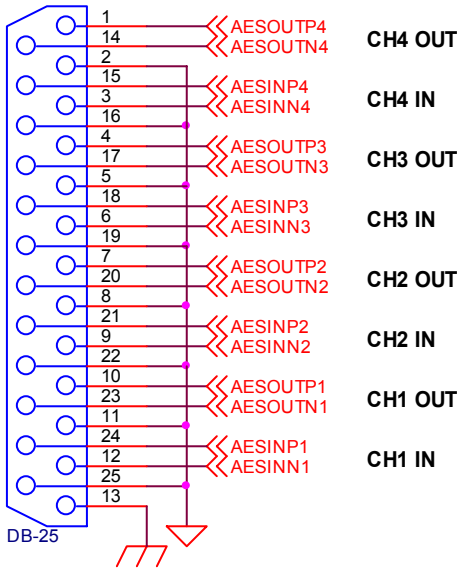

ANALOG AUDIO - INPUT & OUTPUT PINOUTS ARE IDENTICAL

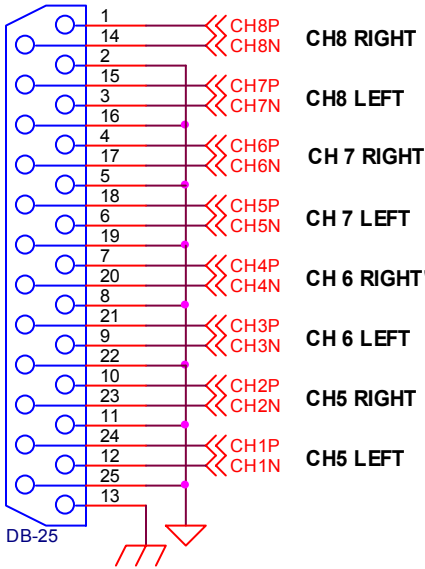

GPM-300 AUDIO INPUT MAPPING DUAL DIGITAL VERSION

INPUT CHANNEL	TYPE	LOCATION
1	DIGITAL	AES 1
2	DIGITAL	AES 2
3	DIGITAL	AES 3
4	DIGITAL	AES 4
5	DIGITAL	AES 5
6	DIGITAL	AES 6
7	DIGITAL	AES 7
8	DIGITAL	AES 8

GPM-300 AUDIO INPUT MAPPING HYBRID ANALOG/DIGITAL VERSION

INPUT CHANNEL	TYPE	LOCATION
1	DIGITAL	AES 1
2	DIGITAL	AES 2
3	DIGITAL	AES 3
4	DIGITAL	AES 4
5	ANALOG	ANALOG IN 1-2 (L/R)
6	ANALOG	ANALOG IN 3-4 (L/R)
7	ANALOG	ANALOG IN 5-6 (L/R)
8	ANALOG	ANALOG IN 7-8 (L/R)

IX. Remote Control Connections

GPM-300 Remote Connections

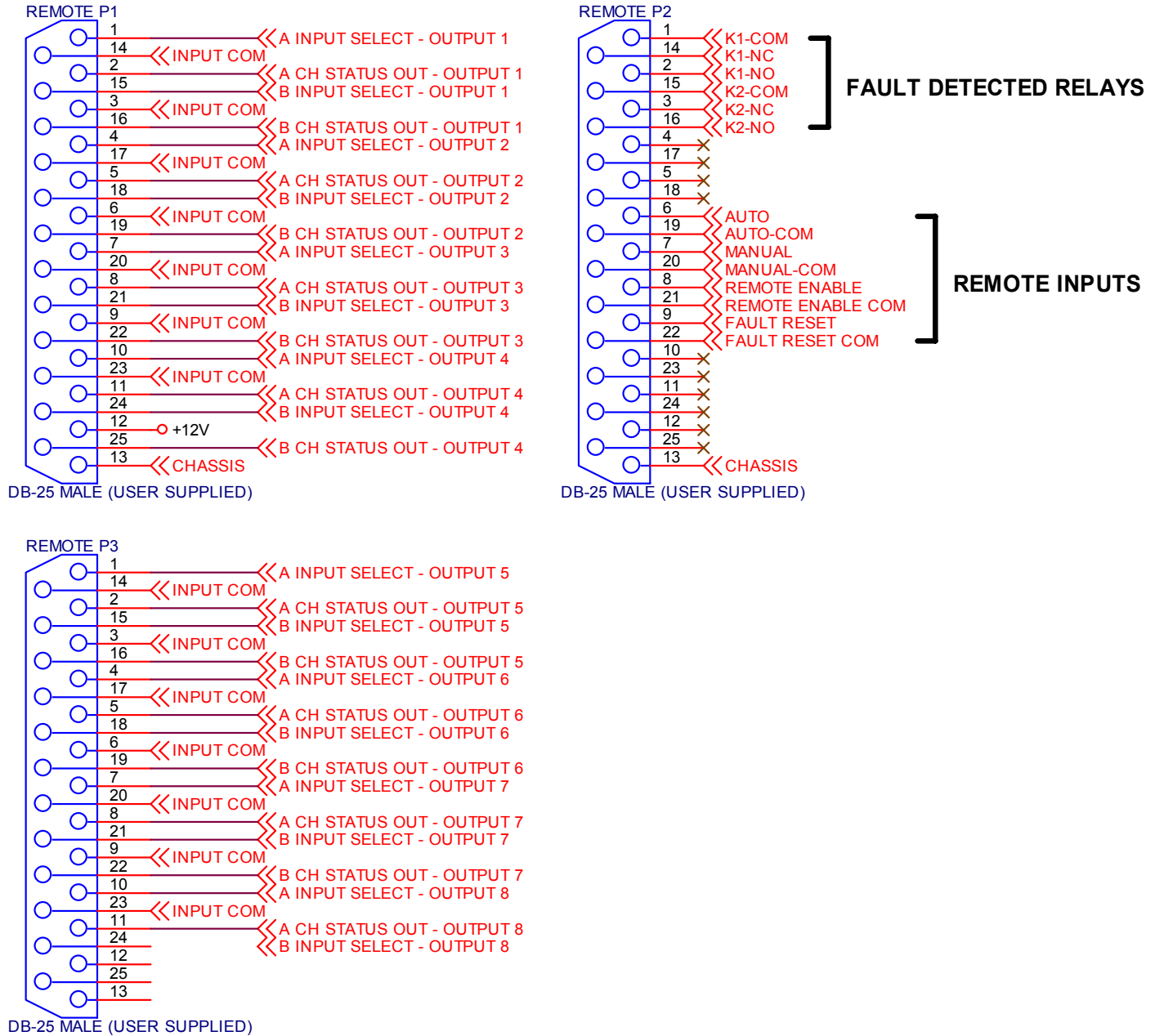

Notes:

1. Status outputs are open collector Darlington transistors capable of sinking 100ma @ 30v DC.
2. Select and remote inputs are momentary closures with internal 4.7K pullup resistors to 5v DC.

3. For Remote Control Operation a connection between Remote Enable pin 8 and Remote Enable Common pin 21 must be made.

This is the standard parallel remote control and status output connection to the GPM-300 series audio switchers. See the next section for direct serial control of the GPM-300 series switchers with EAS equipment.

Sage Endec and Digital Alert Systems DASDEC Serial Interface

The GPM-300 can be serially controlled by Sage Endec EAS Encoder series. To connect and control a GPM-300 with the Sage Endec encoder:

1. Connect a straight through DB9 cable from COM6 of the Sage Endec encoder to the DB9 - RS-232 connector of the GPM-300. To make up your own cable connect review the diagram below for wiring details.

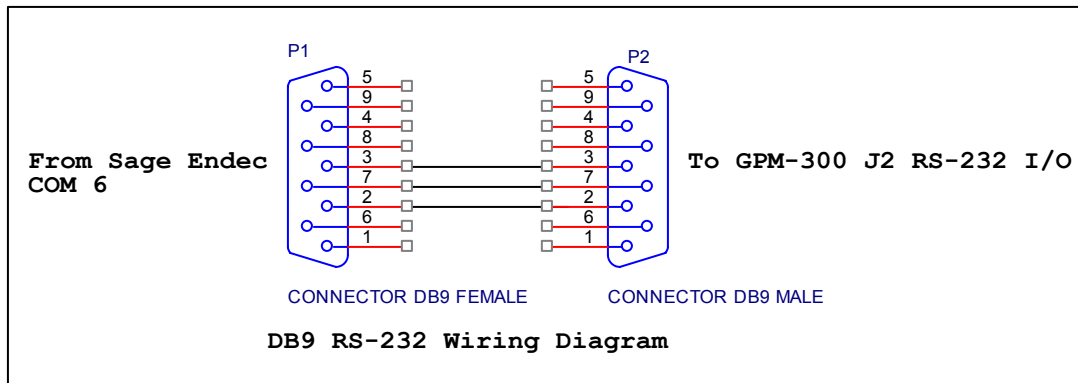

For GPM-300-1, 6 models – ALL AES I/O – Allows multiple AES streams to be interrupted by AES Digital EAS Audio Output

2. Connect program sources to the first three inputs of the GPM-300 unit.
3. Connect the Sage Endec AES output to the 4th AES input of the GPM-300.
4. Select “A” inputs 1, 2, and 3 respectively on the first three GPM-300 outputs.
5. Select “B” input 4 for all four of the first four GPM-300 outputs. – This makes input 4 a common source input used by the Sage Endec encoder.
6. Test individual output selection by choosing each Weekly EAS Station starting with STN 2. STN 1 is the internal AES I/O of the Sage Endec encoder and is not used in this application. As each individual STN test is performed verify that the proper output changes from the pre selected input to input 4 when EAS audio is output from the encoder. At the conclusion of the weekly test the unit will revert to the pre selected input. Keep in mind that STN 2 of the Sage Endec encoder is switched to GPM-300

output #1, STN 3 is switched to GPM-300 output #2, and STN 4 is switched to GPM-300 output #3. GPM-300 Output #4 can be used to monitor the Sage Endec encoder without disturbing the first three inputs by choosing STN 1 Weekly Test only.

Note: that any inputs may be selected for the A inputs in item 4 above. This is merely an example. The GPM-300 will revert back to whatever channel is selected last for the respective output "A" input. This is slightly different operation than the GPIO remote in where the pre programmed A input would be selected. In the EAS serial mode the last channel selected for A input will be reverted to after the EAS operation is finished.

X. Basic Block Diagram of GPM-300

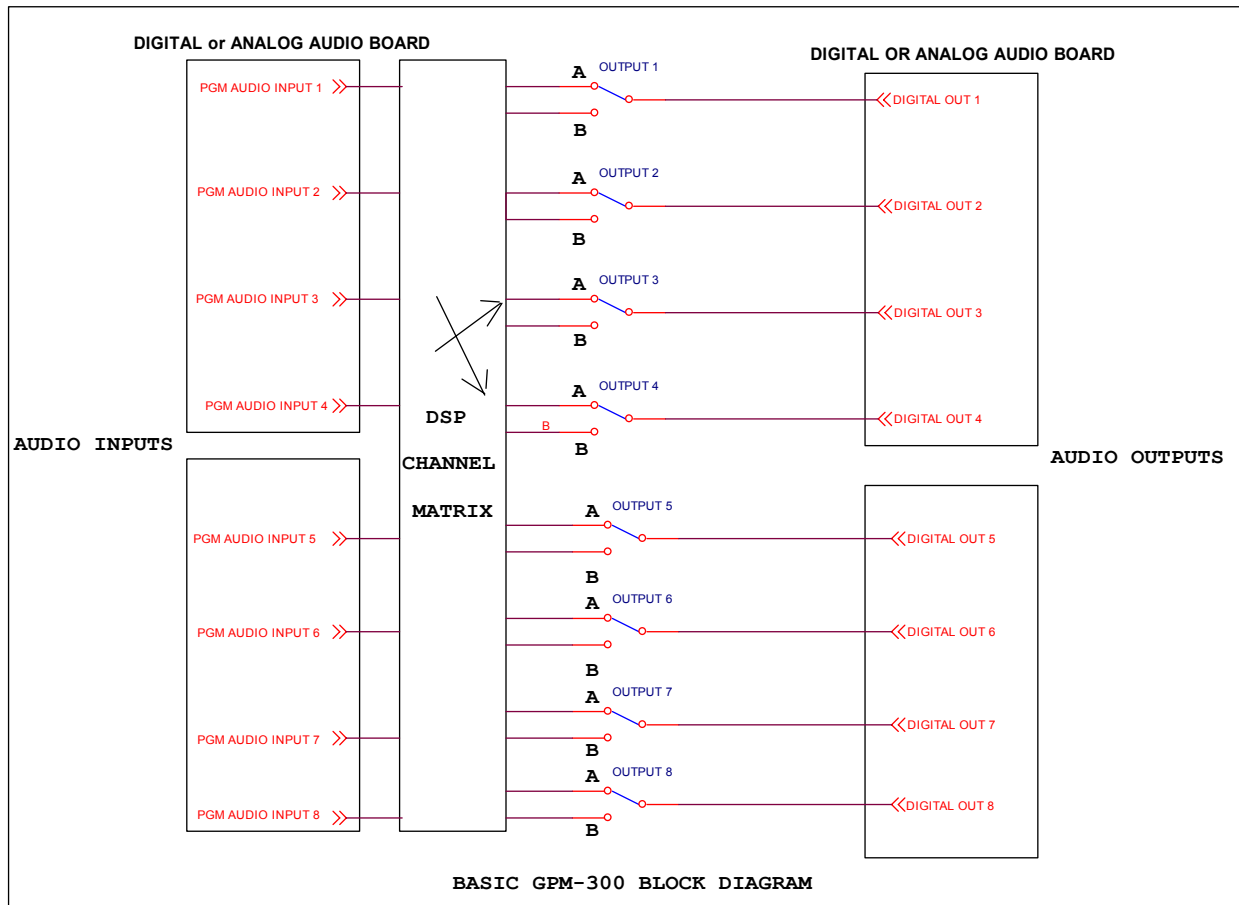

IX. Frame Rate Conversion Switch Selection

The GPM-300 has active frame rate conversion on all AES3 digital inputs. The unit can accept sample rates from 8 KHz to 96 KHz. The frame rate converter then up or down converts the sample rate to the selected sample rate. The GPM-300 is capable of outputting 32, 44.1 or 48 KHz sample rates. The factory default sample rate is 44.1 KHz. To change the sample rate to either 32 or 48 KHz refer to the diagram below. The sample rate converters are located on the AES I/O board. Locate S1 and change SR0, SR1 according to the chart below. Do not adjust any other DIP switch setting as this will result in incorrect operation of the GPM-300. Correct DIP switch settings are provided for convenience.

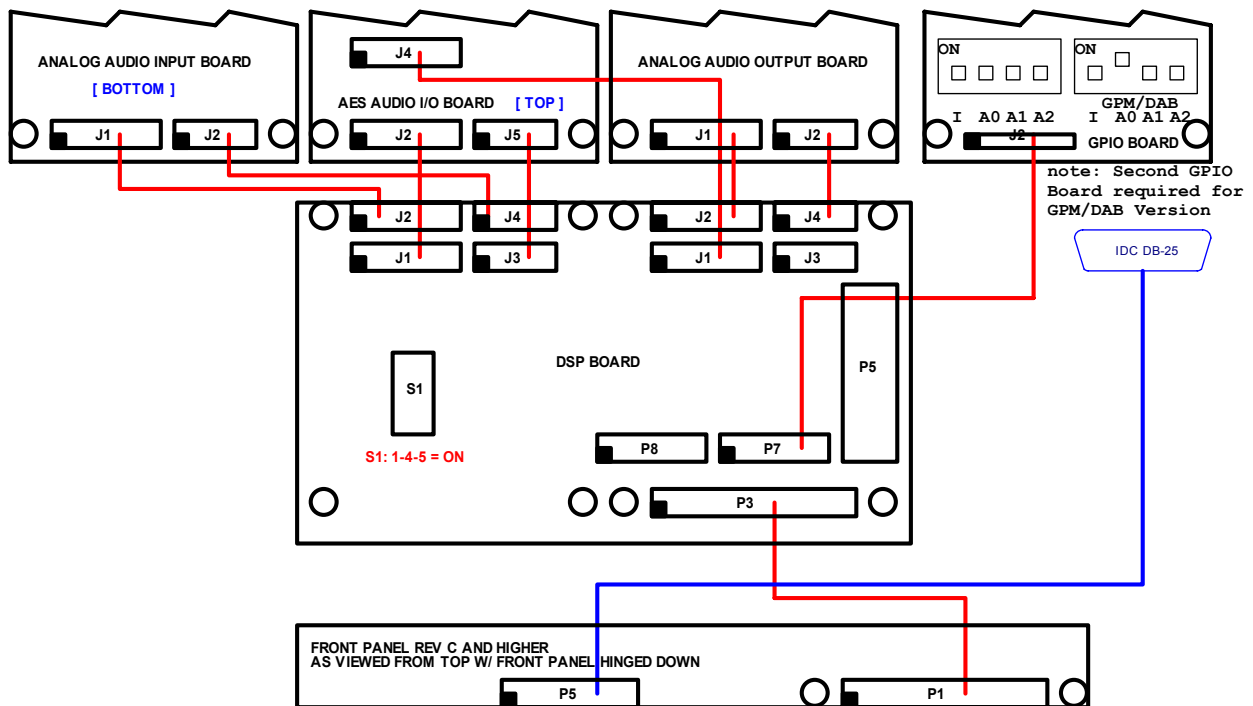

XI. Warranty

Broadcast Devices, Inc. products are warranted against failure due to faulty materials or workmanship for a period of one year from the date of shipment to the ultimate user. The warranty covers repair or replacement of defective parts at the factory, provided the unit has been returned prepaid by the user. All shipments to the factory shall have affixed to the outside of the container a return authorization number obtained from the factory. The above warranty is void if the unit has been modified by the user outside of any recommendations from the factory or if the unit has been abused or operated outside of its electrical or environmental specifications. If customer conducted field tests suggest that the unit may be faulty, whether or not the unit is in warranty, a full report of the difficulty should be sent to Broadcast Devices, Inc. factory at Cortlandt Manor, New York. The office may suggest further tests or authorize return for factory evaluation.

Units sent to the factory should be well packed and shipped to Broadcast Devices, Inc. 2066 E. Main Street, Cortlandt Manor, NY 10567. Remember to affix the R.A. number to the outside of the carton. Any packages received without such R.A. number will be refused. Note: freight collect shipments will also be refused. When the unit has been received, inspected and tested, the customer will receive a report of the findings along with a quotation for recommended repairs, which are found falling outside of the standard warranty. Units returned for in-warranty repairs, which are found not to be defective will be subject to an evaluation and handling charge. In-warranty units will be repaired at no charge and returned via prepaid freight.

Out-of-warranty units needing repair require a purchase order and will be invoiced for parts, labor, and shipping charges.

When ordering replacement part, always specify A) Part Description, and Quantity; B) Date of Purchase, Where Purchased; C) Any Special Shipping Instructions. Always specify a street address, as shipping companies cannot deliver to a postal box.

Broadcast Devices, Inc. is not responsible for any other manufacturer's warranty on original equipment. Nor are we responsible for any failure, damage, or loss of property that may occur due to the installation or operation of our equipment outside of recommended specifications.

Broadcast Devices, Inc. reserves the right to change materials, specifications, and features from time to time.

www.broadcast-devices.com

Broadcast Devices, Inc.

2066 E. Main Street

Cortlandt Manor, NY 10567 Email: Customer.Service@broadcast-devices.com

(914) 737-5032 Tel. (914) 736-6916 Fax.