



Broadcast Devices, Inc.

Technical Reference Manual

SWP-200-1/2 Antenna Switch Controller/RF Power Meter

**Broadcast Devices, Inc.
2066 E. Main Street
Cortlandt Manor, NY 10567**

**Tel. (914) 737-5032
Fax. (914) 736-6916
World Wide Web: www.Broadcast-Devices.com**

**Rev H – July 2010
Firmware 3.7.0 and higher**

Table of Contents

I. Introduction	3
II. Unpacking	3
III. Installation and Connections	4-9
IV. Features and Operation	10-16
V. Optional Communications Interface Information	17-22
VI. Optional Temperature/Pressure Connection Diagram	22-23
VII. Specifications	24
VIII. Warranty	25
IX. Motorized Switch Connection Diagrams	26-27

I. Introduction

The SWP-200 Antenna Switch Control/Power Meter System family of controllers is designed to simplify the connection and operation of 4 port switches in broadcast applications. The SWP-200 is designed to control and sequence switches and transmitters to provide safe and reliable control of the transmitter plant. The SWP-200 automatically “steers” the interlock connections to the transmitters according to the position of the RF switches. The power meter section of the system provides RMS forward and reflected power indication suitable for analog FM, digital power measurement such as needed for in band on channel broadcasting and 8 VSB modulation techniques.

The SWP-200 is an intelligent controller which may be connected to optional RF sensors to provide additional functionality and safety. When equipped with RF sensors, the SWP-200 “Switch Saver” will detect and prevent an attempt to move a switch while RF is present to prevent damage to the switch and/or other equipment.

The SWP-200 provides both forward and reflected power display for a main and auxiliary sensor channel as well as reflected power protection via a proprietary “three strike” algorithm. This algorithm prevents the SWP-200 from responding to transient events such as close-by lightning strikes and avoids unnecessary off-air incidents.

In addition, the SWP-200 is capable of detecting a drop in RF power below a user configured threshold and automatically switching to backup transmitter. Dual switch versions of the SWP-200 are capable of responding to a reflected power fault by automatically moving to a backup antenna.

Basic Description of models:

The SWP-200-1 Series controls one - two position switch assembly.

Basic single switch controller for controlling up to two transmitters connected to up to two loads, typically an antenna and dummy load. – Optional RF sensors available for “Switch Saver” operations, auto switching upon power loss and VSWR 3 strike protection.

The SWP-200-2 Series controls two – two position switch assemblies. - Optional RF sensors available for “Switch Saver” operations, auto switching upon power loss and VSWR 3 strike protection, VSWR detection for switch operation to a standby antenna.

Controls two – two positions switch assemblies with a system mode based state machine. This allows single command *simultaneous* control of both switches when reconfiguration of the system requires both to be moved.

Note: This technical manual covers the installation, configuration and operation instructions for the SWP-200-1 and SWP-200-2 switch controllers.

II. Unpacking and Inspection

Carefully inspect the unit after unpacking and make certain that no damage has occurred during shipping. If damage is noted, contact the shipper immediately and file a claim for damages. Each unit is carefully packed and carries full insurance against damage. Inspect the packing list and make sure that the contents of the package match those described on the packing list.

III. Installation and Connections

Wiring Considerations:

The SWP-200 has the capability to totally automate the control of transmitters and switch operations with the touch of a button. The units have provision to turn transmitters off/on and provide interlock closures. Some applications may require separate transmitter off and on control in addition to interlock closures managing transmitter on/off functions. The contacts are provided for both. Some installations may call for interlock connections only to turn transmitters on and off. It is entirely up to the installer. The flexibility of both methods has been designed in to the SWP-200 series controllers.

Basic Wiring Methodology

Refer to SWP-200 REMOTE COMMAND/STATUS drawing page 7 for the following discussion.

The SWP-200 is capable of automatic transmitter turn –on based on position of switch 1. This feature allows the SWP-200 to turn on either or both transmitters when switch one is moved and the interlock path is re-established.

Interlock inputs are provided for each position of both switches on DB-15 connectors to assist in wiring the interlock string for each mode. Connect any interlock switches associated with each mode in series between the pin associated with that mode and a control/status common pin. Refer to page 8 for connection information for the TX and ANT connectors. The SWP-200 automatically “steers” the interlock connections to the transmitters according to the position of the RF switches. Refer to page 10 for a diagram illustrating interlock steering.

A. SWP-200-1/2 Install the unit in a suitable EIA rack enclosure.

As a safety precaution, never install a switch controller to a switch system that has radio frequency energy present on it or where AC/DC control power is applied. This can be dangerous and can easily damage a switch!

1. Before applying power to the SWP-200-1/2 or to the switch assembly, connect the supplied DB15 connector to the motorized switch plug or strip connector cable. Refer to section VII typical Switch Connections Diagrams section for suggested wiring details for most motorized switches available. If you are attempting to interface a switch assembly not covered in this section please contact the factory for assistance with your switch assembly. The DB15 connection plugs into the SWP-200 “SW 1/2 I/O connector input on the rear of the unit. These connections are the only connections to the switches required except for electrical power. Control of the switches, position status and interlock control are all handled by these cables. Additional switch position and/or interlock connections may be available on the respective manufacturer’s switch connector if desired for some other use.
2. Next, apply power the SWP-200 and observe the front panel. If all connections are made properly and the switches are correctly seated in positions A or B, the front panel display should indicate the present position of the switch assemblies. If the switch assemblies are not connected properly or are in the middle of their travel, the front panel will indicate “Check Switch 1 (2) “Both”. In this case check that the switches are seated properly by applying A.C. power to the switch(es). If a switch is in mid travel it will go to the position that the internal latching relay commands it to be in. Recheck the SWP-200 display for proper position indication. If the SWP-200 still shows “Check Switch” then the most probable cause is a defective interface cable or a problem with the switch electronics.

3. Make remote control, status and transmitter control connections to SWP-200 rear panel remote control connector according to tables on page 6 , 7 and 8. Note that the common connection for command and status is ground. The interlock connections are dry contact relays with 24 VDC 3 Ampere contact ratings which can be interfaced to an external interlock as desired.

SW I/O DB-15 Table 1

Connector Pin#	Connector Pin Designation
1	Command A Output
2	Command A Common
3	Not used
4	+12 VDC
5	+12 VDC
6	Position A Status Input
7	Position B Status Input
8	Chassis Ground
9	Not used
10	Command B Output
11	Command B Common
12	Status Common
13	Status Common
14	Status Common
15	Status Common

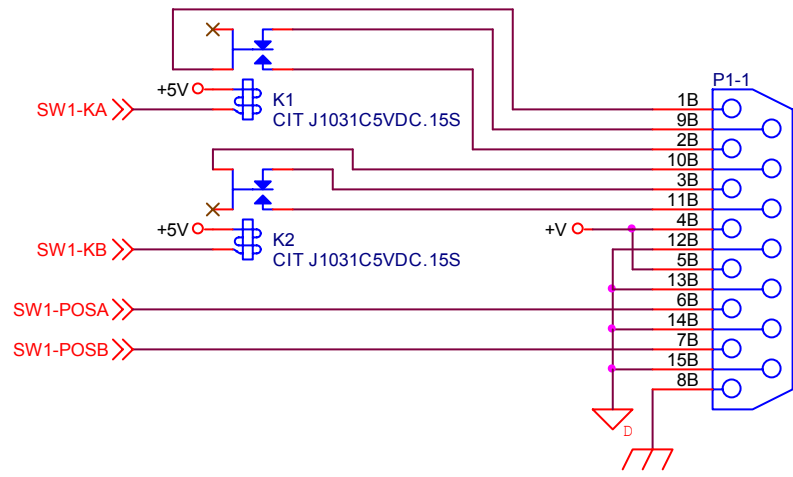

SW I/O DB-15 Pin Out Diagram

TX CTL/Interlock DB-25 Connector Table

Connector Pin#	Connector Pin Designation
1	TX 1 Interlock PATH - COM
14	TX 1 Interlock PATH - NC
2	TX 1 Interlock PATH - NO
15	TX 1 Filament OFF - COM
3	TX 1 Filament OFF - NC
16	TX 1 Filament OFF - NO
4	TX 1 Plate OFF - COM
17	TX 1 Plate OFF - NC
5	TX 1 Plate OFF - NO
18	TX 1 Plate On - COM
6	TX 1 Plate On - NC
19	TX 1 Plate On - NO
7	TX 2 Interlock PATH - COM
20	TX 2 Interlock PATH - NC
8	TX 2 Interlock PATH - NO
21	TX 2 Filament OFF - COM
9	TX 2 Filament OFF - NC
22	TX 2 Filament OFF - NO
10	TX 2 Plate OFF - COM
23	TX 2 Plate OFF - NC
11	TX 2 Plate OFF - NO
24	TX 2 Plate On - COM
12	TX 2 Plate On - NC
25	TX 2 Plate On - NO

Note: That position A interlock relay is energized for position A “selected” (Common and NO connections are made)
 Position B interlock relay is energized for position B “selected” (Common and NO connections are made)

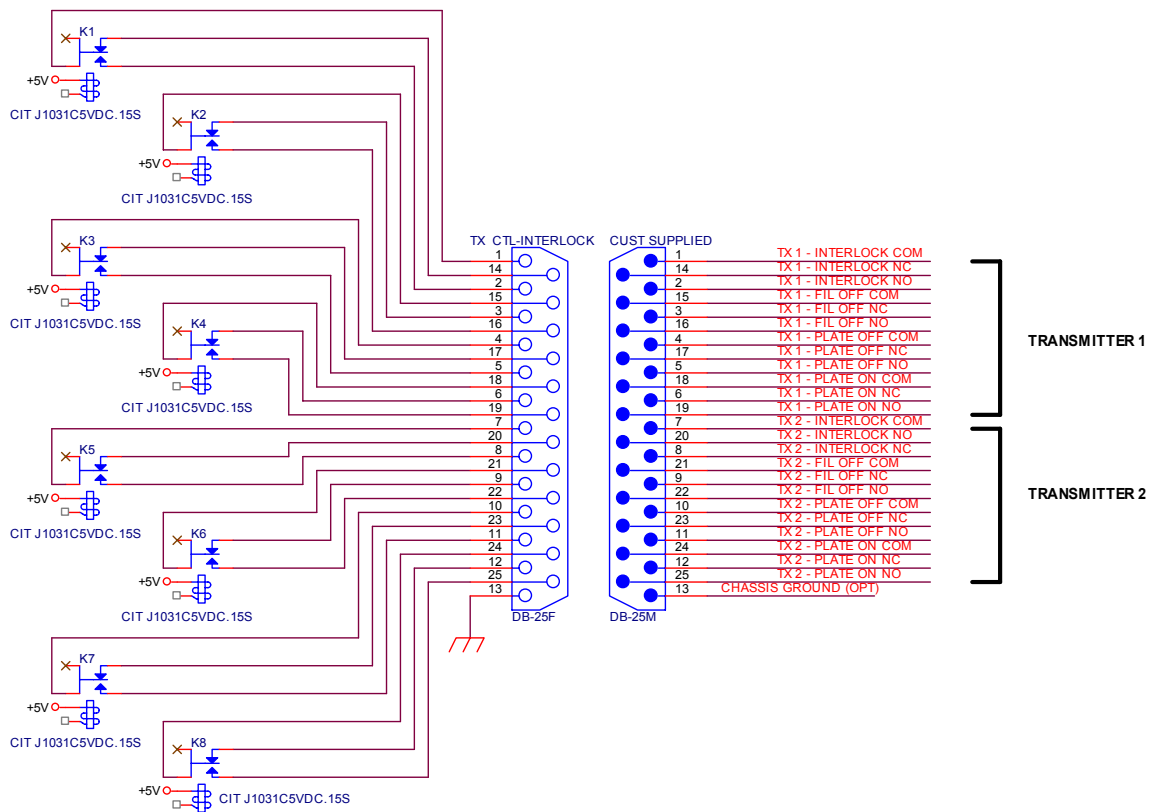

TX CTL/Interlock DB-25 Connector Pin Out Diagram

Remote/Status DB-25 Table

Connector Pin#	Connector Pin Designation
1	TX 1 Air Command – Active Low
14	Control/Status Common – Digital Ground
2	TX 1 Air Status – Active Low
15	TX 2 Air Command – Active Low
3	Control/Status Common – Digital Ground
16	TX 2 Air Status – Active Low
4	TX 1/2 Off Command – Active Low
17	Control/Status Common – Digital Ground
5	TX 1/2 Off Status – Active Low
18	Air TX On Command – Active Low
6	Control/Status Common – Digital Ground
19	Air TX On Status – Active Low
7	TX Manual Command – Active Low
20	Control/Status Common – Digital Ground
8	TX Manual Status – Active Low
21	TX Auto Command – Active Low
9	Control/Status Common – Digital Ground
22	TX Auto Status – Active Low
10	Remote Fault Reset – Active Low
23	Control/Status Common – Digital Ground
11	TX 1 Interlock Status – Active Low
24	AC Pwr Loss Input – Active Low
12	+12V
25	TX 2 Interlock Status – Active Low
13	Chassis Ground

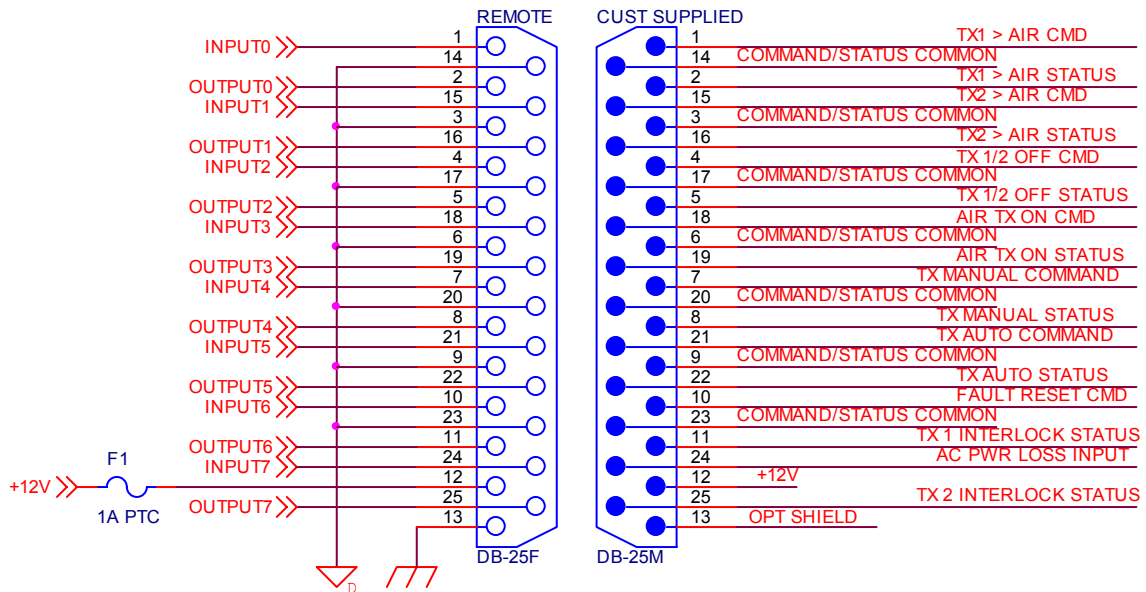

Remote Command/Status DB-25 Pin Out Diagram

Interlock Path Connectors – “SWITCH 3 and 4” connectors

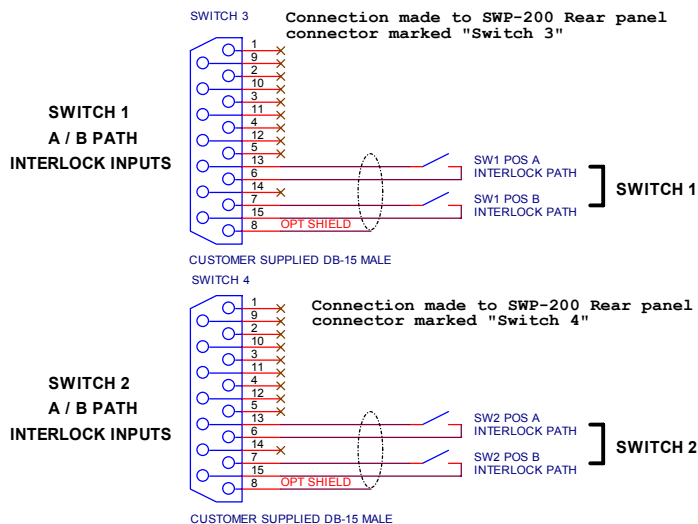

22 AWG CABLE RECOMMENDED

NOTES:

1. TRANSMITTER INTERLOCK PATH WILL BE CLOSED WHEN CORRESPONDING SWITCH INTERLOCK INPUT PATH IS COMPLETED.
2. IF PATH IS NOT REQUIRED, JUMPER INPUT ON CONNECTOR.

Remote Power Indication Hookup

To remotely monitor forward and reflected power a D.C. sample for each is provided on a three position connector that is plugged into the DPS-100 Power Sensor. The connector is marked “F” for forward power, “G” for ground and “R” for reflected power. The output is a D.C. representation that is linear in dB for power. 1 dB power change represents a D.C. voltage change of 76.4 mV. Make connections to suitable remote control metering inputs full scale D.C. output is 4.6 V.D.C.

Directional Coupler Installation and Sensor Connection

1. Determine a suitable location for the supplied EIA flanged precision directional coupler. The coupler should be placed in the load path such as the antenna or in the case of a dual coupler system a dummy load path.
2. Attach the supplied BDI DPS-100 Power Sensor to the directional coupler with the supplied hose clamps.
3. Connect the directional coupler outputs to the DPS-100 sensor as shown in the diagram below. Be sure to use the external fixed attenuators if supplied. Observe the diagram below for proper connection information. Standard cable length is 25 feet. Please contact the factory for custom cable lengths.

DPS-100 Attachment to supplied directional coupler

Each DPS-100 Power sensor is attached to a directional coupler with supplied pipe clamps. Attach the DPS-100 and connect the supplied RF cables as shown in the diagram below.

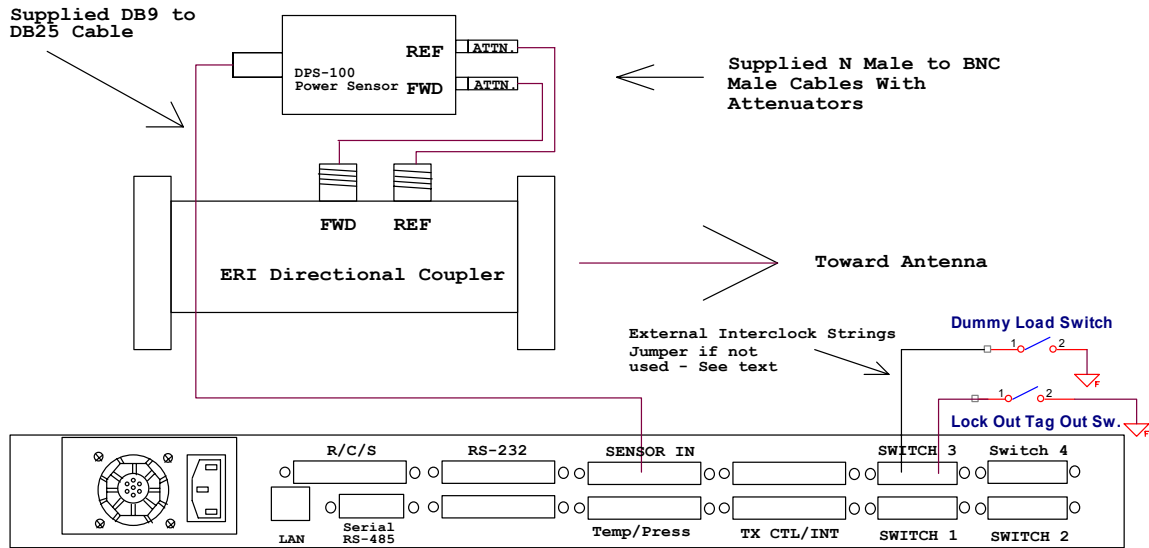

Note about Directional coupler ports:

The forward port of a directional coupler is denoted as being the N connector closest to the direction from which the forward power is coming from. The reflected power sample is the N connector closest to the direction of the load. See the diagram below.

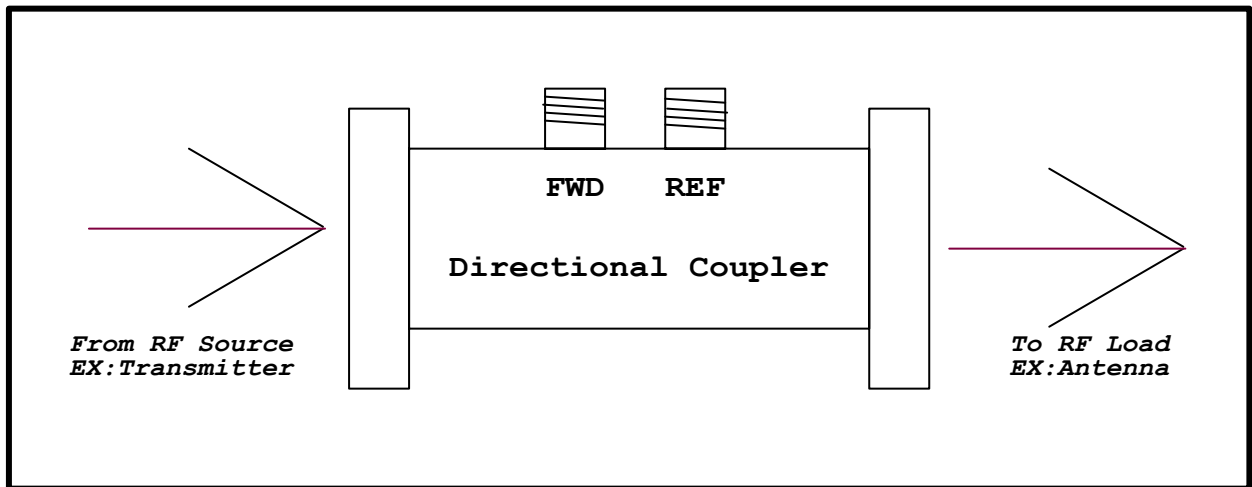

IV. Programming Features and Operation

The SWP-200-1 is pre programmed for single switch operation and requires only minimal programming. The SWP-200-1 is factory configured to switch between 2 transmitters.

To enable full functionality of the enhanced features a number of parameters must be configured during the installation process. All programming can be accomplished from the front panel and an internal jumper is provided to allow front panel programming to be disabled to prevent accidental changes. This jumper is factory installed. To remove this jumper thus locking the programming function, remove the top cover, locate the jumper which is located on the right rear of the front panel P.C. board which closest to the power supply connector for this board.

To enter the programming menu, press the green CHECK key in the center of the keypad. Pressing the CHECK key again will exit the programming mode and save all settings which were modified. Pressing the red X key will exit the programming menu and discard all changes.

Once in the programming mode pressing the LEFT or RIGHT arrows will sequence through the list of programmable parameters. Pressing the UP or DOWN arrows will sequence through the available options for the currently displayed parameter.

The following parameters are user configurable:

Auto Switching – Enable/disable automatic backup transmitter switching based on RF power level. If auto switching is enabled an “A” will be displayed in the lower left corner of the display. If auto switching is disabled, an “M” will be displayed.

Auto Return – Enable/disable automatic return to the main transmitter if the backup transmitter fails to turn on or if the backup transmitter power is less than the Auto Switch Level. If the SWP-200 executes an Auto Return, it will enter the Manual mode to prevent undesirable subsequent switching operations. If auto return is enabled, an “R” will be displayed to the right of the auto switch indicator while auto switch is enabled.

Auto Switch Time – Sets the amount of time that the main transmitter must remain below the user configurable level before the SWP-200 will switch to the backup transmitter.

Auto Switch Level – Configures the level at which the SWP-200 will automatically move to the backup transmitter.

Safe Switch Level - Configures the maximum amount of RF power that may be present for the SWP-200 to move a switch. Increasing the safe switch level will cause the SWP-200 to “ignore” more RF and should be done with caution. *Certain situations such as collocated transmitters with antennas that couple power into the antenna connected to the SWP-200 may necessitate increasing this level. It is recommended that you contact the factory for further guidance if you encounter such a situation to prevent damage to the switch or other equipment.*

Reflected Power Level – Configures the reflected power level at which the SWP-200 three strike counter will disable the air transmitter interlock.

Serial Remote Control Enable/Disable – This menu item allows the operator to either enable or disable serial and/or remote LAN remote control of TX ON/OFF, SWITCH CONTROL, ERROR RESET functions. If enable is chosen, remote control of these functions is allowed through the rear panel RS-232 connector and the remote LAN interface if supplied. Remote status of forward/reflected power, temperature, pressure, interlock and fault status/reset is always available through the RS-232 and remote LAN connections regardless of this setting.

The following parameters for use with BDI DPS-100 RMS Sensor

FWD Coupling – The FWD coupling value of the line section including any external attenuators used to prevent the sample from the FWD port from exceeding 0dbm at rated transmitter output.

REF Coupling – The REF coupling value of the line section including any external attenuators used to prevent the sample from the REF port from exceeding 0dbm should a fault occur which would result in full power being reflected.

The above settings are factory set and should not require adjustment. Adjustment of these parameters will affect accuracy of power measurement and should be done with factory assistance!

Basic Theory of Operation:

Upon front panel or remote control command the SWP-200 operation sequence is as follows:

1. Command from the CPU board is issued to the transmitter control/interlock board to issue a PLATE OFF/TX off commands and open the safety interlocks of both transmitters connected to the four port switch.
2. Approximately 2 seconds after these commands are issued the SWP-200 issues a switch command to the appropriate pin of the SWx I/O interface connector.
3. Once the switch reaches its commanded position the SWP-200 receives new position information from the switch via the SWx I/O interface connectors and issues an interlock closure command. Approximately 2 seconds later the chosen “Position relay” closes and then issues a Plate On/TX “ON” command to the transmitter feeding the on air position. The SWP-200 connects the correct A/B interlock path inputs to the transmitters for the path they are feeding. The circuit shown below is typical of what may be encountered in a typical installation. If no additional interlock connections are needed simply connect the respective A/B

INTERLOCK STEERING - TX1 ON AIR

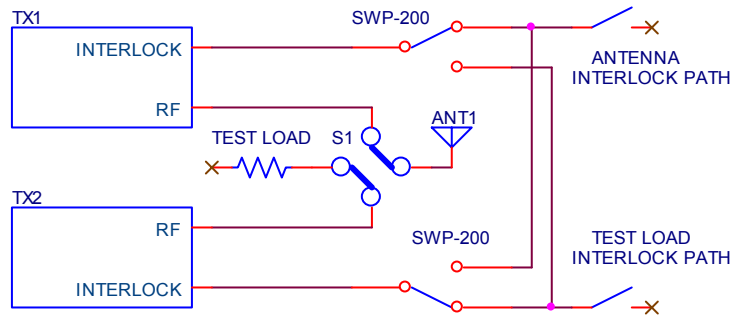

INTERLOCK STEERING - TX2 ON AIR

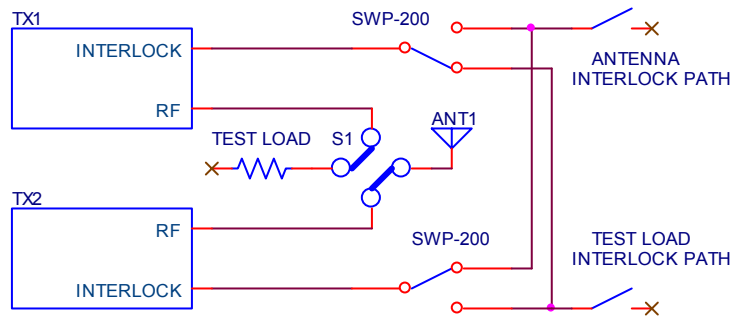

interlock inputs to common.

Note: If the 4 port switch fails to reach the commanded position due to mechanical or power failure, the SWP-200 will hold the interlock connections in the open position and will not issue a TX “ON” command.

The SWP-200 will reflect the actual position and status of the four port switch. If it becomes necessary to manually move the four port switch to a new position the SWP-200 will sequence the interlock and other transmitter control relays as from a front panel or remote control command to the SWP-200.

Switch-Saver RF sensing:

This function requires an optional DPS-100 RF power sensor DC line section sensor or connection to the forward power DC output of the transmitter remote metering for forward and reflected power if available.

The SWP-200 (when equipped with RF detection) will examine the RF level present on the switch to prevent movement of any switch when RF is present. This prevents damage to a switch or other equipment due to incorrect/damaged transmitter interlock connections or transmitter malfunction. *The Safe Switch Level configures maximum level that may be present for the SWP-200 to allow manual or automatic movement of a switch. While this level can be changed by the user, we do not recommend increasing the level above the default 1 W level without consulting with the factory prior to such a change.*

Automatic Transmitter Switching:

This function requires an optional DPS-100 RF power sensor, D.C line section sensor or connection to the forward power DC output of the transmitter remote metering for forward and reflected power if available.

The SWP-200 automatic transmitter function can (if enabled) switch a backup transmitter to the air antenna when the RF power from the currently selected air transmitter falls below the user configured TX Auto Level. The TX Auto Time parameter sets the delay during which the SWP-200 will wait for the power to return to a level above the TX Auto Level before initiating an automatic switching operation. When the RF power of the air transmitter drops below the TX Auto Level (user configured) for longer than the TX Auto Time (user configured) the SWP-200 will execute the transmitter turn off sequence, connect the other transmitter to the air antenna by moving SWITCH 1 to the alternate position and subsequently executing the air transmitter turn on sequence. If the TX Auto Return function has been enabled by the user, the SWP-200 will monitor the RF power level to determine if the “backup” transmitter power is above the TX Auto Level. If the backup transmitter fails to turn on or if it does not produce more power than the original (main) transmitter, the SWP-200 will return to the original transmitter. Note: The SWP-200 will only execute the TX Auto Return function ONCE. This function ensures that the station remains on-air with the highest possible power given the state of the two connected transmitters.

Note: The SWP-200 will NOT attempt to auto switch if the SWP-200 has opened the air transmitter Interlock due reflected power in excess of the reflected power level setting.

Automatic Antenna Switching: (2 – Switch SWP-200 models only)

This function requires an optional DPS-100 RF power sensor for forward and reflected power.

When the SWP-200 Three-strike algorithm detects a reflected power level in excess of the user configured REF PWR LEVEL, the SWP-200 will execute the transmitter turn off sequence, and connect antenna B as

the air antenna by moving SWITCH 2 to the B position. The SWP-200 will then execute the air transmitter turn on sequence.

SIMPLIFIED SYSTEM INTERCONNECTION DIAGRAM SINGLE SWITCH CONFIGURATION

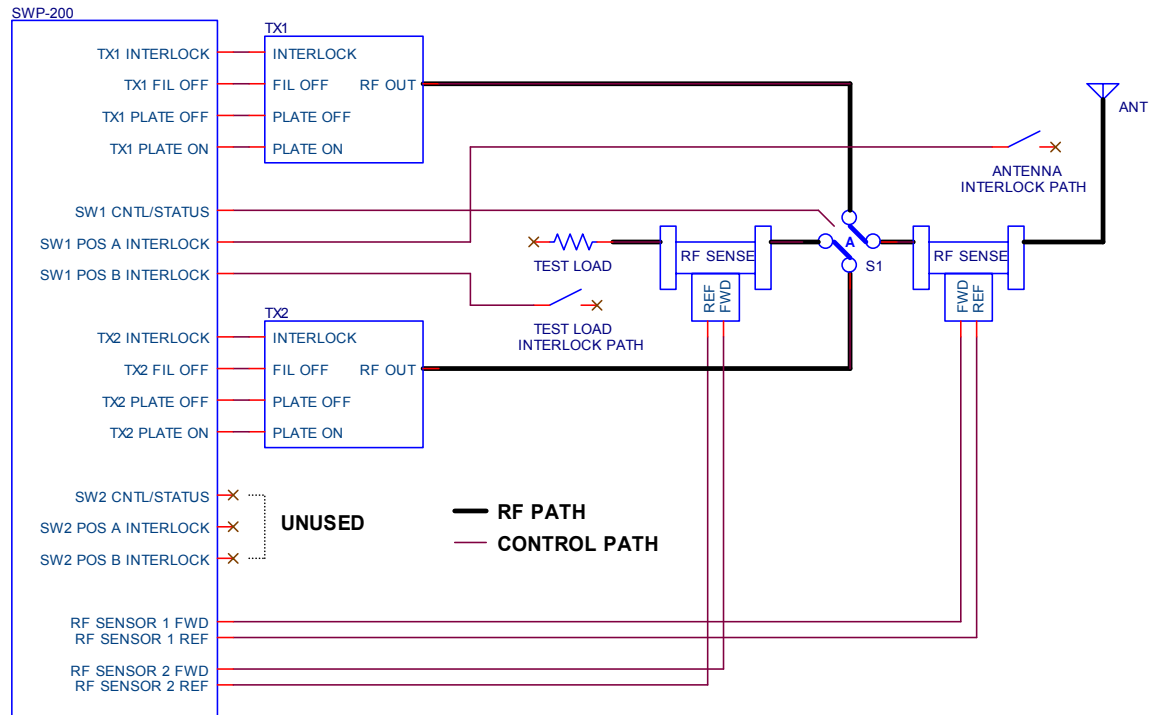

Front Panel Operation:

To select a transmitter or antenna simply press the desired mode button. The SWP-200 has four mode buttons. F1 and F2 select transmitters 1 and 2 respectively. F3 is TX 1+2 Off and F4 is Air TX On. F3 turns both transmitters off and defeats auto switching operation. F4 will turn on the transmitter selected to the air path. **Note:! When placing the SWP-200 in Auto Switch mode the F4 button must be depressed to initiate the Auto Switch function. – Also note that it is not possible to place the SWP-200 in Auto mode unless RF power above switch threshold is indicated in the air path.**

When depressing a mode all interlock relays are opened (de energized). TX OFF commands if used are issued next. Next the attached switch will move to the desired position. The interlock relays are then closed (Re energized). Last, the TX selected to the active load such as an antenna is commanded on if this connection is made.

Remote operation of the SWP-200 series functions identically to the front panel operation discussed above. Momentary closure to common of the appropriate pin on the remote connector will cause the SWP-200 to operate as described above. Serial and LAN remote control functions operate in identical fashion to front panel and GPIO remote control.

The SWP-200 normally displays data from the main (air) RF sensor. To view the auxiliary RF Sensor information press the left arrow key. To return to the main menu press the left arrow key again. After 5 minutes the SWP-200 will automatically return to the main screen.

The lower left corner of the main screen will display “M” when auto switching is disabled and “A” when auto switching is enabled. When one or more three strike counter events have been recorded, the lower left hand corner of the display will have 1 to 3 bell-shaped characters to indicate the number of strikes. After the 3rd strike, the air transmitter interlock will be latched in the open position until the three strike counter is reset from the front panel using the “X” key or by the remote reset input. The three strike counter can be cleared at any time by pressing the “X” key.

Remote Operation:

Remote commands are issued to the SWP-200 by connecting the command pin associated with that function to command common using a momentary contact. Status feedback is provided via an open collector driver which is active low (sinking) when the associated function is enabled. Refer to page 6 TX CTL/Interlock Connection table for connection information.

The following command inputs and status outputs are provided on the rear panel of the SWP-200 for remote control:

TX 1(2) TO AIR - Selects the transmitter which will be connected to the SW1 Position A (air) load. The associated status pin indicates which transmitter is selected to the air position.

TX 1+2 OFF – Turns OFF both transmitters by issuing plate / filament off commands. The associated status output indicates when both transmitters have been commanded OFF. Issuing this command will cause the SWP-200 to suspend automatic transfer if enabled.

AIR TX ON – This command will close both interlock paths and issue a plate on command to the transmitter which is selected to the AIR position. The associated status output will be active when the air transmitter is on.

TX MANUAL – This command suspends automatic transmitter switching by the SWP-200. When the SWP-200 is in the manual mode the associated status output will be active. In this mode switch operations will only occur with front panel or remote control actuation.

TX AUTO – This command will activate the SWP-200’s automatic transmitter switching function. When automatic switching is enabled the TX AUTO status pin will be active. NOTE: The SWP-200 requires the user to issue an AIR TX ON command to turn on the transmitter if it is not already on. For safety reasons it WILL NOT automatically issue TX ON when placed in TX AUTO mode.

TX 1(2) INTERLOCK STATUS – These status pins will be active when the interlock path to the associated transmitter is closed. The status pin reflects the state of whichever interlock path is connected to each transmitter based on the position of the 4 port switch.

REMOTE FAULT RESET – This input resets the SWP-200 Three Strike Counter to re-enable transmitter interlocks after a reflected power fault. This input is only active after a “3rd Strike” and will not reset the three strike counter unless it has reached the 3rd strike. This allows the operator to view the 1st and 2nd strike indicators to be aware of a possible intermittent condition. The front panel fault reset is used to clear the counter prior to the 3rd strike.

AC PWR LOSS INPUT – This input may be connected to the normally closed contacts of a relay which is energized when power is applied to the transmitter. A loss of power will close the contacts to inhibit the SWP-200 from attempting to switch transmitters before backup power stabilizes or if AC power has been lost to both transmitters. This closure must be present for the duration of the AC power loss event. **DO NOT UNDER ANY CIRCUMSTANCES MAKE CONNECTION TO 120 VAC DIRECTLY!!**

The following remote commands and status outputs apply only to the SWP-200-2 switch model:

AIR TX TO ANT 1 (2) – This command will select the associated antenna to be connected to the air (A) position of switch 2. The associated status pins will indicate which antenna is selected as the air antenna.

ANT MANUAL – This command suspends the automatic antenna switching function of the SWP-200. The associated status pin will become active indicating that the SWP-200 is in MANUAL mode.

ANT AUTO – This command will activate the automatic antenna switching function of the SWP-200.

Local and Remote Monitoring of System Parameters via RS-232 or LAN with optional SWP-200 LAN-100 Communications module

Local monitoring via RS-232 Port or USB to RS-232 adapter

1. The SWP-200 connects to a PC “COM” port using a standard modem cable. Connect the 25 pin modem connector to the rear of the SWP series chassis connector marked “RS-232”. **Note: A “null modem” type cable will not work due to the crossing of transmit and receive data lines.**
2. Connect the other end of the cable to a computer with a suitable serial port with a 9 or 25 pin connector matching the PC COM port.
3. Start Hyper Terminal or other terminal emulation program and set proper com port
4. Enter the following parameters for a communications session:
Data bits: 8, no parity bit, 1 stop bit, Use 38.4 kB/sec data rate and no flow control.
5. Terminal emulation should be set to “Auto”.
6. Begin the session and the local computer screen will prompt for a password. The default password is password all lower case.
7. Once the password has been properly entered the system will begin to send data to the local computer updating the screen about once every 5 seconds.
8. If a fault occurs the operator will be prompted to perform a reset. Follow the directions on screen to reset the fault. If the fault is cleared the system will go back to normal operation. If not a fault will be indicated again and the site should be visited as a fault has occurred that cannot be reset remotely.
9. To activate the remote control menu hold CTRL and press Q. A menu displaying available remote control functions will be displayed as shown in the pictorial on page 23 of this manual.

V. Optional Communications Interface Information

If the BDI P/N LAN-100 communications interface option is supplied the SWP-200 can be configured for local area network connection and serial RS-232 local connection. To configure the SWP-200 for LAN operation, connect the LAN interface to a local router with category 5 local area network cable. Next, open a browser window and enter the default IP address for the SWP-200. **The factory default IP address is: 192.168.1.107**

The SWP-200 factory default settings do not have a user name or password. Hit [ENTER] [ENTER] to proceed to the main configuration menu.

To change the IP address of the SWP-200, click the NETWORK tab on the right side.

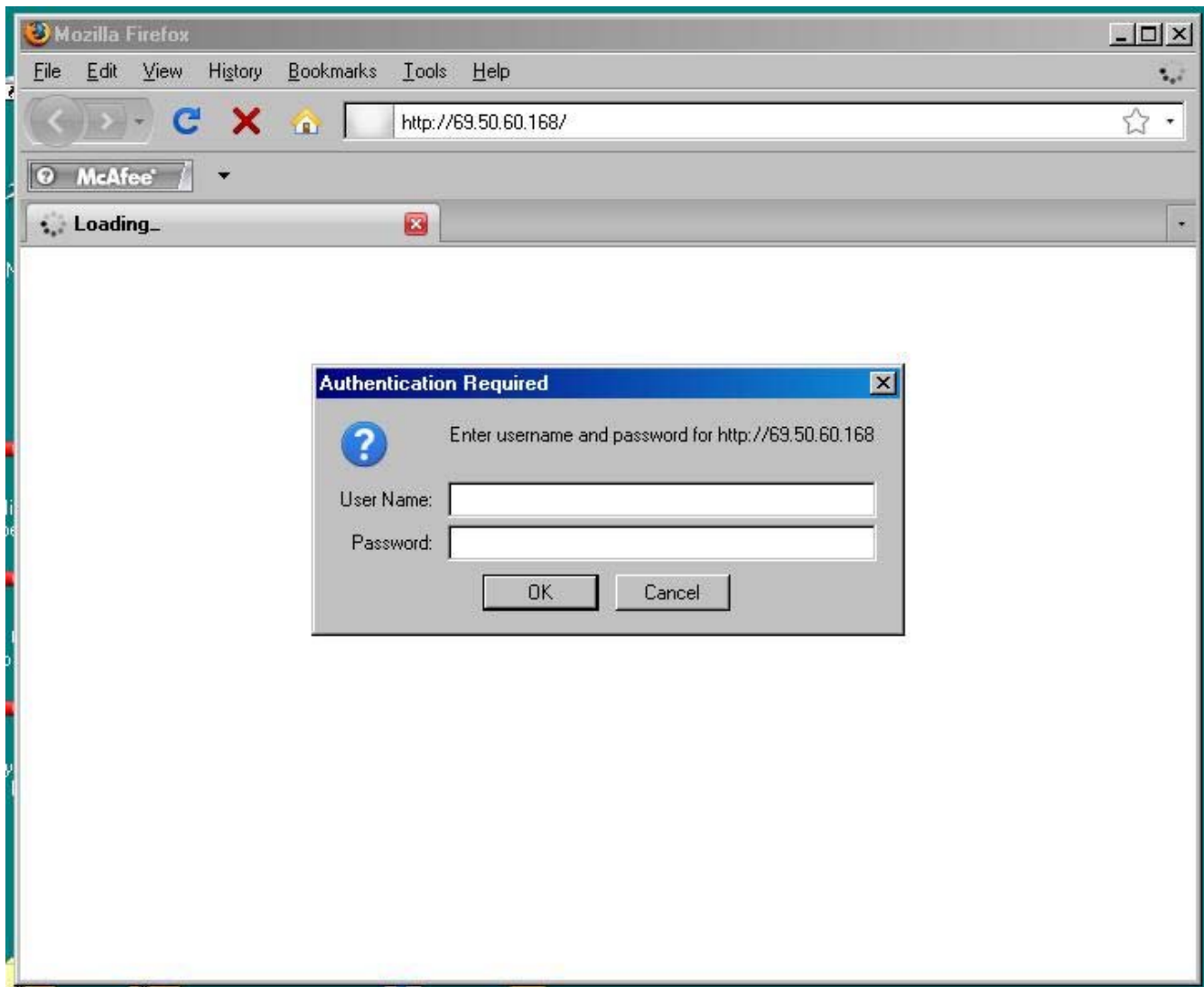

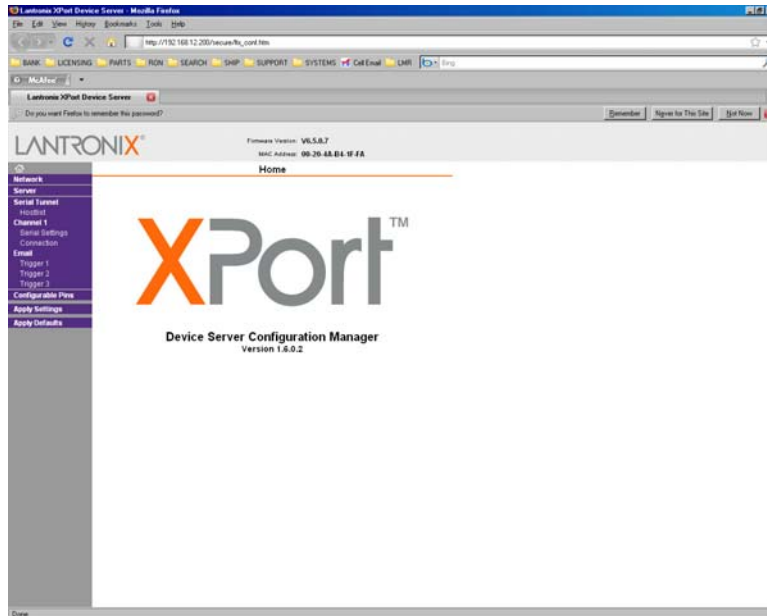

Once you click past the authentication screen the screen below should appear

This screen allows the user to change the IP address, subnet mask and default gateway to match local LAN configuration. Contact your network administrator to obtain the correct settings. Click the [OK] button after changes are made. The SWP-200 is capable of automatically obtaining its IP configuration from a DHCP server however this may result in difficulty “locating” the SWP-200 or may inhibit routing requests from outside a firewall to the SWP-200 for remote access.

NOTE: Be sure to record the new IP address before applying settings (see below). Failure to record the new settings may cause difficulties in locating the SWP-200.

The SWP-200 default password for remote access is “bdi”. Please be sure that the [Caps Lock] key is not enabled or the password will not be accepted. The password may be changed or disabled by clicking the [Connection] tab.

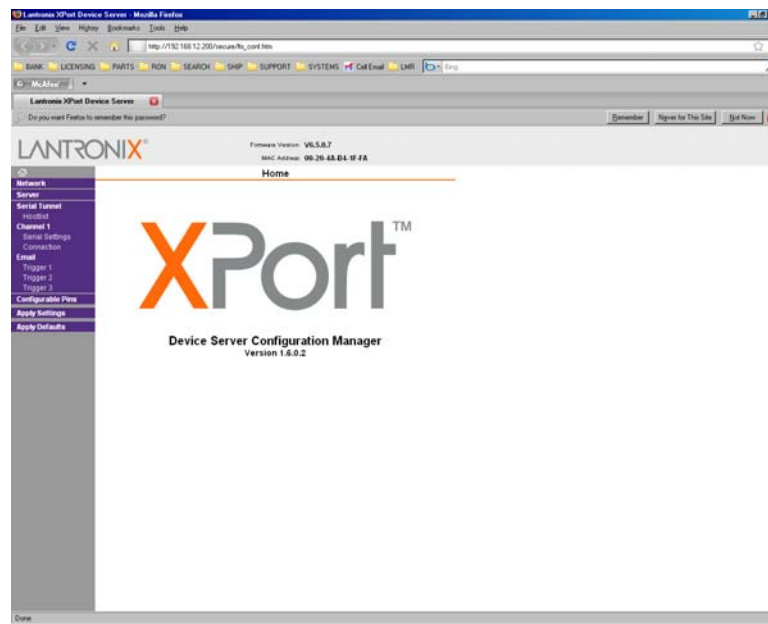

Lantronix XPort Device Server - Mozilla Firefox

File Edit View History Bookmarks Tools Help

http://69.50.60.168/secure/ltx_conf.htm

McAfee

Lantronix XPort Device Server

LANTRONIX[®] Firmware Version: V6.5.0.7
MAC Address: 00-20-4A-B4-1F-FA

Connection Settings

Channel 1

Connect Protocol
Protocol: TCP

Connect Mode

Passive Connection:
Accept Incoming: Yes
Password Required: Yes No
Password: bdi
Modem Escape Sequence Pass Through: Yes No

Active Connection:
Active Connect: None
Start Character: 0x0D (in Hex)
Modem Mode: None
Show IP Address After RING: Yes No

Endpoint Configuration:
Local Port: 10001
Remote Port: 0
Auto increment for active connect:
Remote Host: 0.0.0.0

Common Options:
Telnet Com Port Cntrl: Disable
Terminal Name:
Connect Response: None
Use Hostlist: Yes No
LED: Blink

Disconnect Mode
On Mdm_Ctrl_In Drop: Yes No
Check EOT(Ctrl-D): Yes No
Hard Disconnect: Yes No
Inactivity Timeout: 0 : 0 (mins : secs)

OK

The passive connection password may be changed to the user's preferred password. The SWP-200 may also be configured to not require a password for remote monitoring by checking the NO option next to "Password required".

To save your changes click the “Apply Settings” tab on the left side of the screen. NOTE: If you exit the configuration menu without clicking the “Apply Settings” tab your changes will be lost.

To allow remote access to the SWP-200 your router and firewall must be configured to allow requests to **PORT 10001** to pass to the IP address configured for the SWP-200. Failure to do so will prevent access to the SWP-206 from outside the local network.

SWP-200 Remote LAN Access

To access the SWP-200 remotely a terminal emulator capable of TCP/IP operation is required. Hyper Terminal (provided with Win XP) is one such program however many free and commercial programs are capable of accessing the SWP-200. The example below uses Hyper Terminal.

Step 1: Run Hyper Terminal. Hyper Terminal is located in PROGRAMS- ACCESSORIES- COMMUNICATIONS in Windows XP.

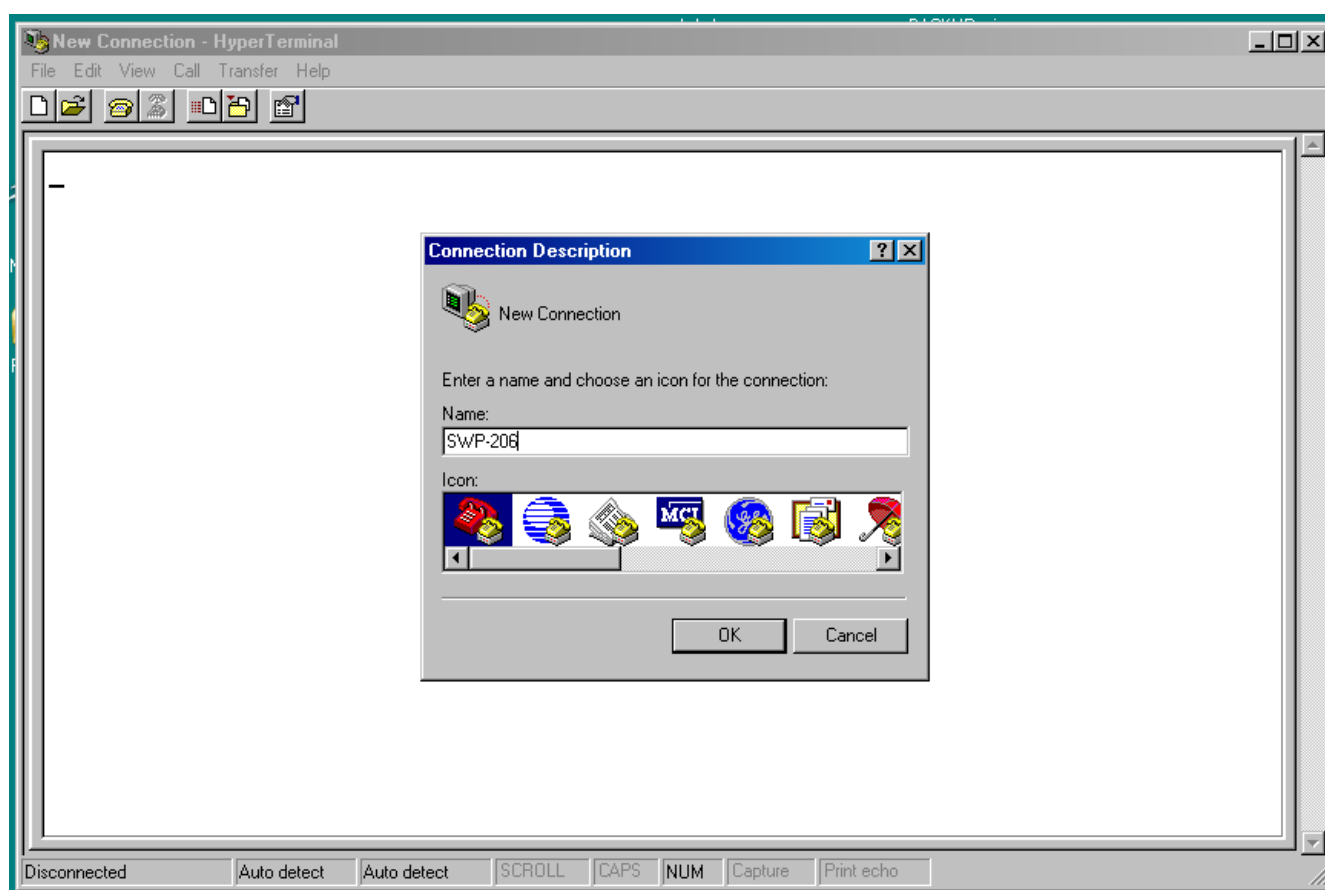

Hyper Terminal will prompt for a Connection Name. Enter a name for this connection such as “SWP-200”

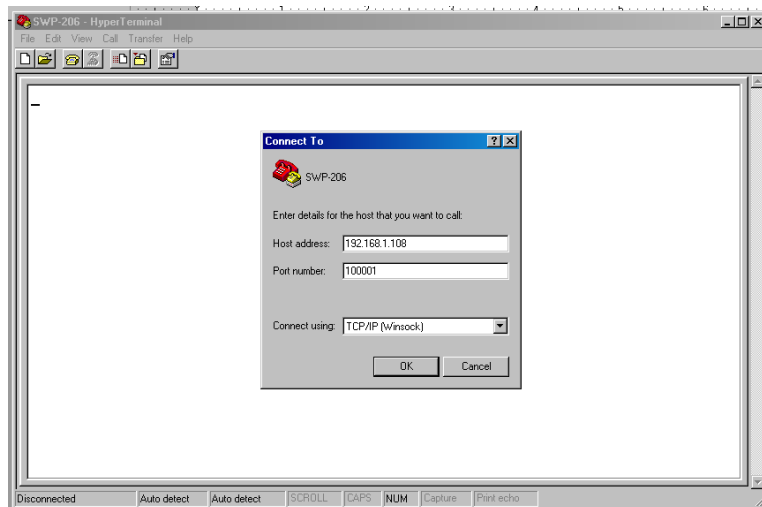

Hyper Terminal will request the configuration information necessary to connect to the SWP-200. Enter the SWP-200 IP address in the Host Address. Enter 10001 as the Port Number. Select TCP/IP (Winsock) for the Connect Using option and click “OK”.

Hyper Terminal will now establish a connection with the SWP-200 and prompt for the SWP-200 remote access password

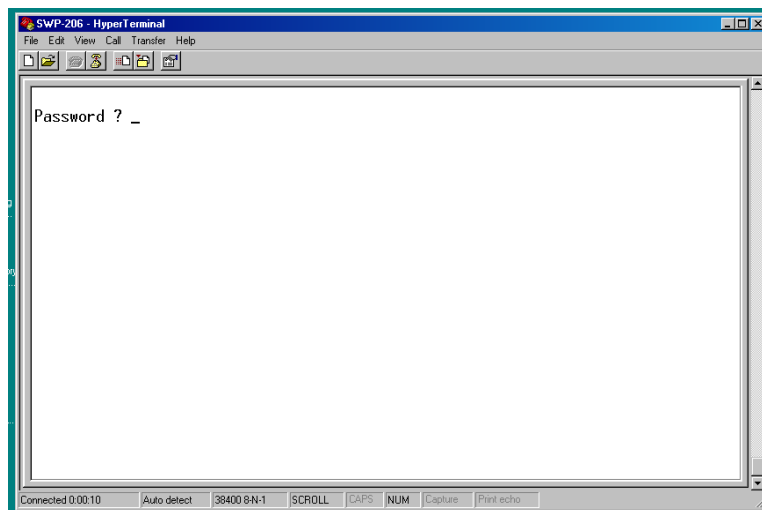

Enter the default or user configured password followed by [ENTER]. If the password is entered correctly the SWP-200 will clear the screen and begin sending remote monitoring data which is refreshed every 4 seconds.

To stop monitoring the SWP-200 exit Hyper Terminal using the usual Windows FILE-EXIT commands. When exiting Hyper Terminal for the first time after configuring for an SWP-206 connection you will be prompted to save the configuration. Doing so will allow easy access in the future. In addition, the “.ht” file saved by Hyper Terminal can be dragged to the desktop or a shortcut created for instant access.

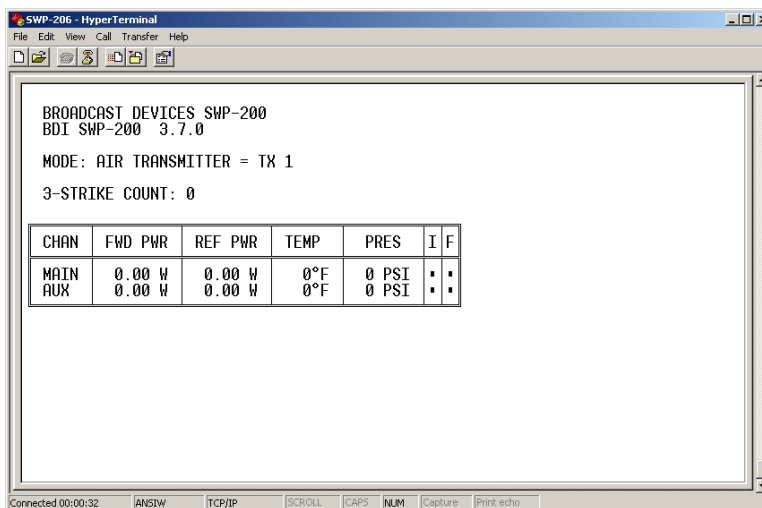

Hyper Terminal screen with serial control menu “OFF”

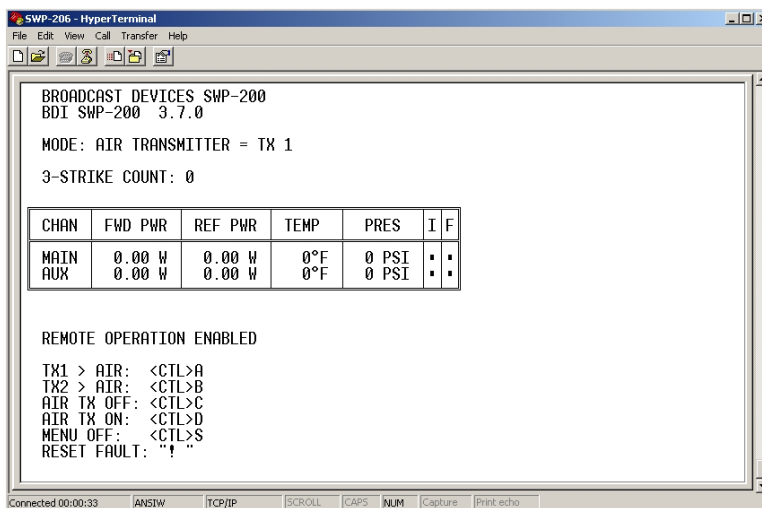

Hyper Terminal screen with serial control menu “ON”

VI. Optional Temperature/Pressure Connection Diagram

The SWP-200 series RF power monitor/switch controller can now be equipped to monitor up to two temperature sensors using the BDI P/N TMP-100 temperature sensor and two pressure sensors using the BDI P/N PSW-100 pressure sensor. A separate connection to the SWP-200 is provided via a DB-25 connector on the rear of the unit marked “T/P”. The TMP-100 and PSW-100 are supplied pre wired and plug directly into the cable assembly provided. The TMP-100 utilizes a three position connector and the PSW-100 utilizes a DB9 connector. Simply connect the sensors to the provided cable and plug the other end of the cable into the SWP-200 T/P connector receptacle.

Temperature and pressure can be monitored from the front panel by advancing the left arrow key until the temperature and pressure screen appear. Temperature and pressure indications are also available via the optional LAN-100 communications interface and the RS-232 connection at the rear of the unit.

When the temperature and pressure option are ordered from BDI a pre assembled and tested cable of 25 foot length is supplied. Connection information is provided below.

Only the “Main” connections are shown for simplicity.

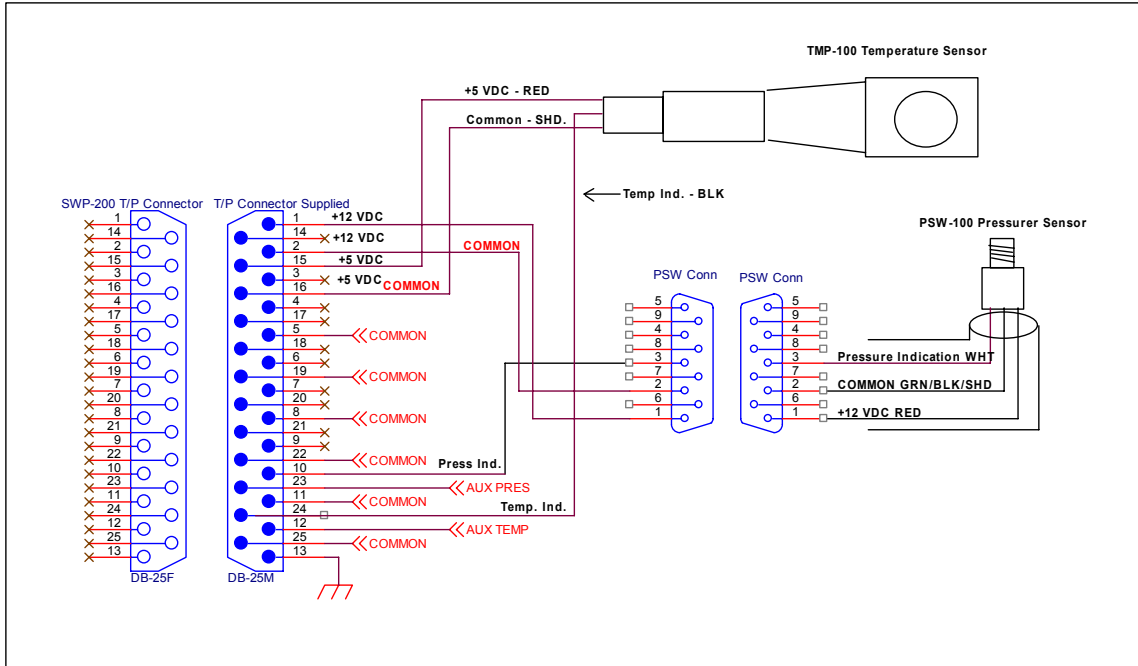

T/P Connection Diagram

VII. Specifications

SWP-100-1/2

Power Indication:	Watts/Kilowatts accuracy within +/- 5% of reading
Control Input	Momentary contact to ground
Control Output to Switch	Dry relay form C contact closure Contact Rating 24VDC @6 A.
Status Output	Open collector output – Active Low
Connector Control in/Status out	DB-25 Female
Connector Type Control to Switch	DB-15 Female
Interlock/TX Control	DB-25 Female
RS-232	DB-25 Female
RS-485 (Optional)	DB-9 Female
LAN connection	Standard Ethernet Connector - 8 conductor
Physical Specification	19" L X 1.75" H X 10" D – Standard EIA rack enclosure
Electrical Requirements	100-240 VAC 50-60 Hertz
Environmental	0 – 60 degrees C. non condensing atmosphere

VIII. Warranty

Broadcast Devices, Inc. products manufactured for Electronics Research, Inc. are warranted against failure due to faulty materials or workmanship for a period of two years from the date of shipment to the ultimate user. The warranty covers repair or replacement of defective parts at the factory, provided the unit has been returned prepaid by the user. All shipments to the factory shall have affixed to the outside of the container an R. A. number obtained from the factory. The above warranty is void if the unit has been modified by the user outside of any recommendations from the factory or if the unit has been abused or operated outside of its electrical or environmental specifications. If customer conducted field tests suggest that the unit may be faulty, whether or not the unit is in warranty, a full report of the difficulty should be sent to Broadcast Devices, Inc. factory at Cortlandt Manor, New York. The office may suggest further tests or authorize return for factory evaluation.

Units sent to the factory should be well packed in the original packing if possible and shipped to Broadcast Devices, Inc. 2066 E. Main Street, Cortlandt Manor, NY 10567. Remember to affix the R.A. number to the outside of the carton. Any packages received without such R.A. number will be refused. Note: freight collect shipments will also be refused. When the unit has been received, inspected and tested, the customer will receive a report of the findings along with a quotation for recommended repairs, which are found falling outside of the standard warranty. Units returned for in-warranty repairs which are found not to be defective will be subject to an evaluation and handling charge. In-warranty units will be repaired at no charge and returned via prepaid freight.

Out-of-warranty units needing repair require a purchase order and will be invoiced for parts, labor, and shipping charges.

When ordering replacement part, always specify A) Part number or Description, and Quantity; B) Date of Purchase, Where Purchased; C) Any Special Shipping Instructions. Always specify a street address, as shipping companies cannot deliver to a postal box.

Broadcast Devices, Inc. is not responsible for any other manufacturer's warranty on original equipment. Nor are we responsible for any failure, damage, or loss of property that may occur due to the installation or operation of our equipment outside of recommended specifications.

Broadcast Devices, Inc. may from time to time make changes to the materials used in the manufacture of its equipment and reserves the right to do so without further notice.

IX. Typical Switch Connection Diagrams

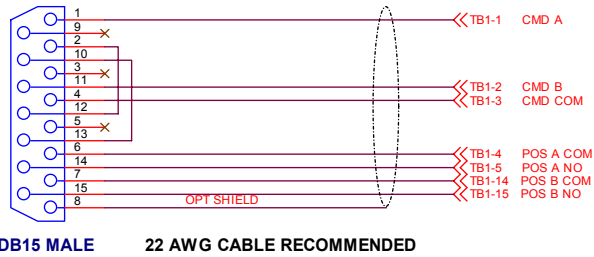
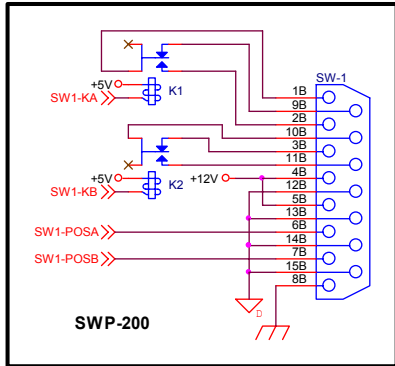

ERI SWITCH

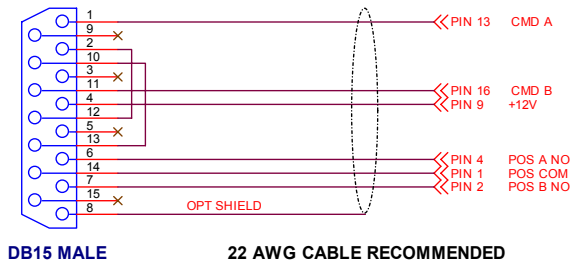
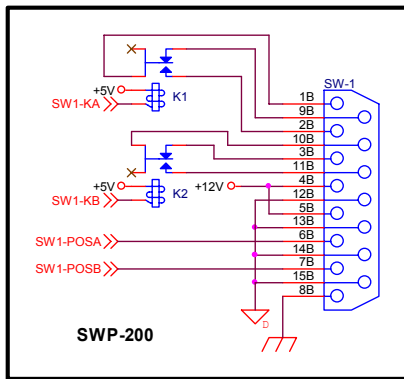
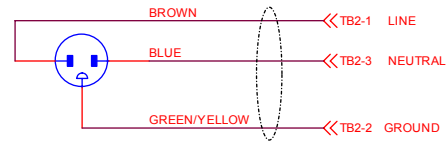

DELTA 67XX SERIES SWITCH

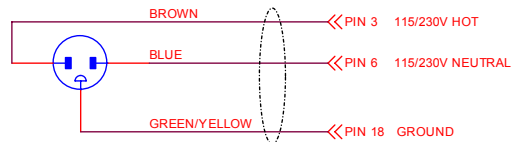

NOTE:
SWITCH MUST HAVE DELTA D42-87-1 12V RELAY KIT INSTALLED.

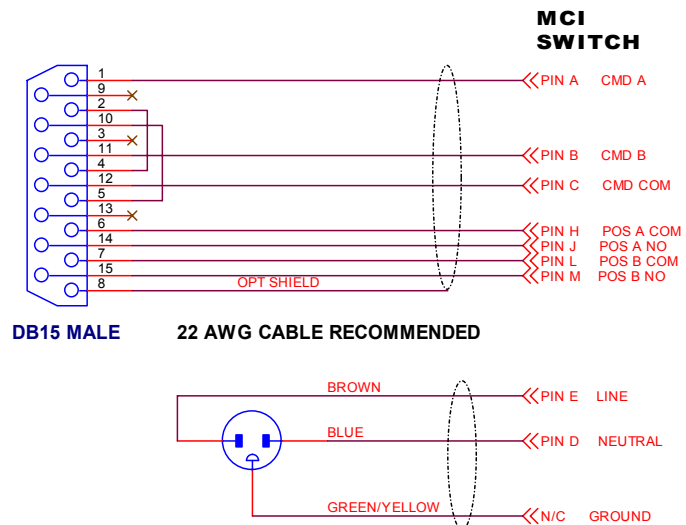
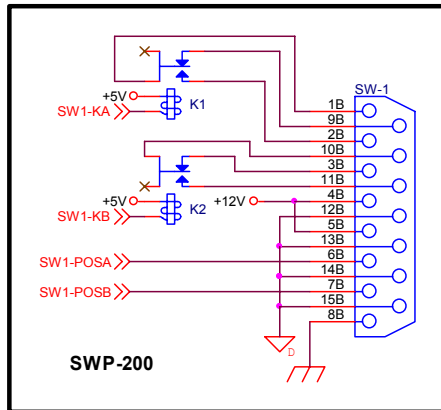
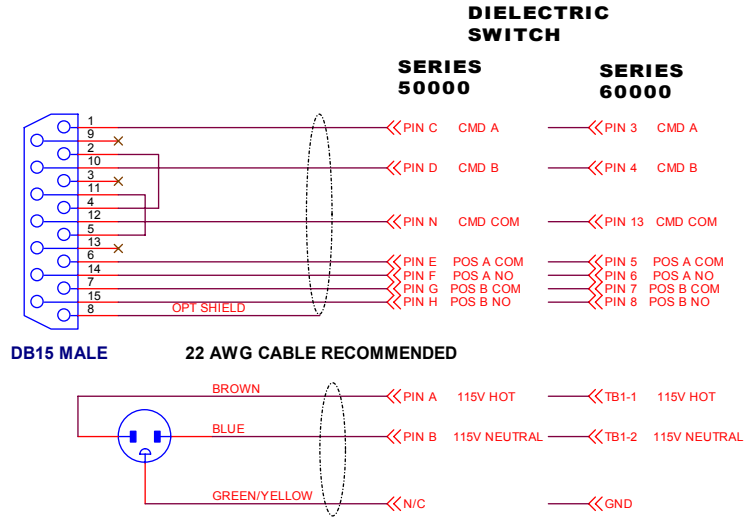
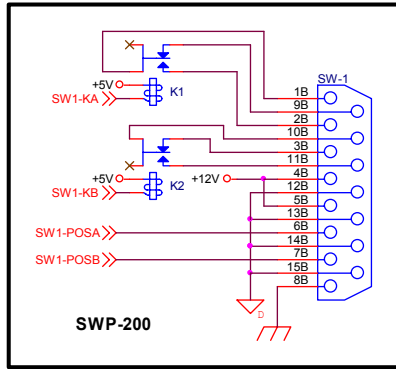

NOTES:

1. CONNECTOR: MIL TYPE MS3102A2214P
2. SWITCH MUST HAVE K1 INSTALLED FOR 12VDC OPERATION.
3. K1 P/N: 7/8" & 3 1/8" SWITCHES: DS2E-ML2-DC12V - ALLIED 788-1057
4. K1 P/N: 4 1/16" & 6 1/8" SWITCHES: KUL11D15D-12 - ALLIED 886-0129