



**Broadcast Devices, Inc.**

***CTD-300 Composite Decoder/  
AES Generator***

**TECHNICAL REFERENCE MANUAL**

**Broadcast Devices, Inc.  
Tel. (914) 737-5032  
Fax. (914) 736-6916**

**REV: A 07/06**

**[www.Broadcast-Devices.com](http://www.Broadcast-Devices.com)**

## **Table of Contents**

### **The CTD-300 Composite Decoder/AES Generator**

#### **I. Introduction**

- A. Unpacking and Inspection**
- B. General Description**

#### **II. Specifications**

#### **III. Installation**

#### **IV. Warranty**

#### **V. Schematic Diagrams**

- A. Functional Diagram**
- B. Setup Diagram**
- C. CTD-300 Schematics**

## Introduction

The CTD-300 Composite Decoder/AES Generator is intended to be used to convert an analog composite base band stereo waveform into a pair of AES3 digital outputs. The CTD-300 will accept the selected composite signal, decode it back to left/right which with proper jumper selection can be routed to the rear panel XLR connectors or convert it to a pair of AES3 compatible streams suitable for input to digital exciter equipment. Suggested uses include converting any composite stereo generator or STL to an AES signal compatible with modern digital AM/FM digital exciters. Analog output is a balanced +4 dBm left/right output for analog decoder applications if AES output is not needed. See the setup diagram at rear of this manual for more information.

### A. Unpacking and Inspection

Carefully unpack the unit after receipt and inspect for damage that may have occurred during shipping. If damage is noted, contact the shipper immediately and file a damage claim. The contents of the package have been insured to cover total replacement cost. Make certain that the package contents are the same as noted on the packing slip. If not, contact Broadcast Devices, Inc.

### General Description

The CTD-300 contains a high quality, phase locked loop stereo decoder, analog to digital converter and AES transmitter. Stereo composite audio is routed to the stereo decoder where it is converted back to analog left/right and then routed to a 24 bit analog to digital converter. The output of the converter is then routed to an AES transmitter/DA where it is outputted on a pair of XLR connectors at the rear of the chassis. In this configuration it is possible to drive a pair of digital input exciters simultaneously with the same composite source. It is also possible to output a balanced +4 dBm left/right output to the XLR connectors if AES output is not needed.

## Specifications

Composite Input Impedance:	100K unbalanced – Accepts 3.5 Volt RMS composite
Output Impedance:	110 ohm balanced - digital 600 ohms balanced – analog
Number of outputs:	2 – AES3 or 1 – analog left/right
Sample rate:	32, 44.1, 48 or 96 KHz
Pre/de emphasis:	50 or 75uS selectable.

## II. Installation

### A. Initial Configuration Digital Output

1. Apply normal composite level audio to the B.N.C. connector input. Connect the AES outputs to suitable AES equipped exciters or BDI AES-302 digital audio switcher/DA and observe modulation on a suitable modulation monitor. If level adjustment is necessary, there are two options for adjusting level. If the overall level needs adjustment, turn VR1 up or down as necessary to maintain desired modulation level. If balance between left and right channels is not correct, this can be compensated for by adjusting VR2 and 3. VR2 is left channel and VR3 is right channel. Refer to the setup diagram at the rear of the manual for location of these controls.
2. The CTD-1/SDM-1 is normally shipped from the factory with 75 uS pre and de emphasis capability for North American applications and 50 uS for European applications. Jumpers JP3, 4 are installed for pre emphasis. In the case of 50 uS pre emphasis a pair of capacitors is supplied to be placed across JP3 and JP4. These capacitor jumpers are found in a plastic bag inside the unit. For de emphasized or flat frequency response audio output, remove jumpers JP3 and JP4. Pre emphasis is defeated as a factory default.

3. Sample rate adjustment. The CTD-300 is normally shipped configured for 44.1 KHz sample rate. Other sample rates are possible including 32, 48 and 96 KHz. To adjust sample rate to other than 44.1 KHz, consult the sample rate chart on the setup diagram page at the rear of the manual.

#### Initial Setup for Analog output

1. Follow steps 1-4 above
2. Solder a jumper across the space for resistor R87. This removes the reference bias that the A/D converter requires. If this step isn't performed a 2.5 V.D.C. bias voltage will appear on pins 2 and 3 of the XLR connector.
3. Remove power and locate L1, 2, 3,4D jumpers on CTD-1 board and remove them.
4. Install jumpers across L1,2,3,4A just to the left of the pads in the above step. With this change, the output presented to the rear XLR connectors will be a +4 dBm balanced stereo output. Output 1 is left channel and output 2 is right channel.

#### **IV. Warranty**

Broadcast Devices, Inc. products are warranted against failure due to faulty materials or workmanship for a period of one year from the date of shipment to the ultimate user. The warranty covers repair or replacement of defective parts at the factory, provided the unit has been returned prepaid by the user. All shipments to the factory shall have affixed to the outside of the container an R. A. number obtained from the factory. The above warranty is void if the unit has been modified by the user outside of any recommendations from the factory or if the unit has been abused or operated outside of its electrical or environmental specifications. If customer conducted field tests suggest that the unit may be faulty, whether or not the unit is in warranty, a full report of the difficulty should be sent to Broadcast Devices, Inc. Call or email the factory first! The office may suggest further tests or authorize return for factory evaluation.

Units sent to the factory should be well packed and shipped to Broadcast Devices, Inc. Call 914-737-5032 or email [customer.service@broadcast-devices.com](mailto:customer.service@broadcast-devices.com) for a R.A. (return authorization) number and ship to address instructions prior to shipping. Remember to affix the R.A. number to the outside of the carton. Any packages received without such R.A. number will be refused. Note: freight collect shipments will also be refused. When the unit has been received, inspected and tested, the customer will receive a report of the findings along with a quotation for recommended repairs, which are found falling outside of the standard warranty. Units returned for in-warranty repairs which are found not to be defective will be subject to an evaluation and handling charge. In-warranty units will be repaired at no charge and returned via prepaid freight.

Out-of-warranty units needing repair require a purchase order and will be invoiced for parts, labor, and shipping charges.

When ordering replacement part, always specify A) Part number or Description, and Quantity; B) Date of Purchase, Where Purchased; C) Any Special Shipping Instructions. Always specify a street address, as shipping companies cannot deliver to a postal box.

Broadcast Devices, Inc. is not responsible for any other manufacturer's warranty on original equipment. Nor are we responsible for any failure, damage, or loss of property that may occur due to the installation or operation of our equipment outside of recommended specifications.

## **V. Schematic Diagrams**

- A. Functional Diagram
- B. Setup Diagram
- C. CTD-300 Schematic

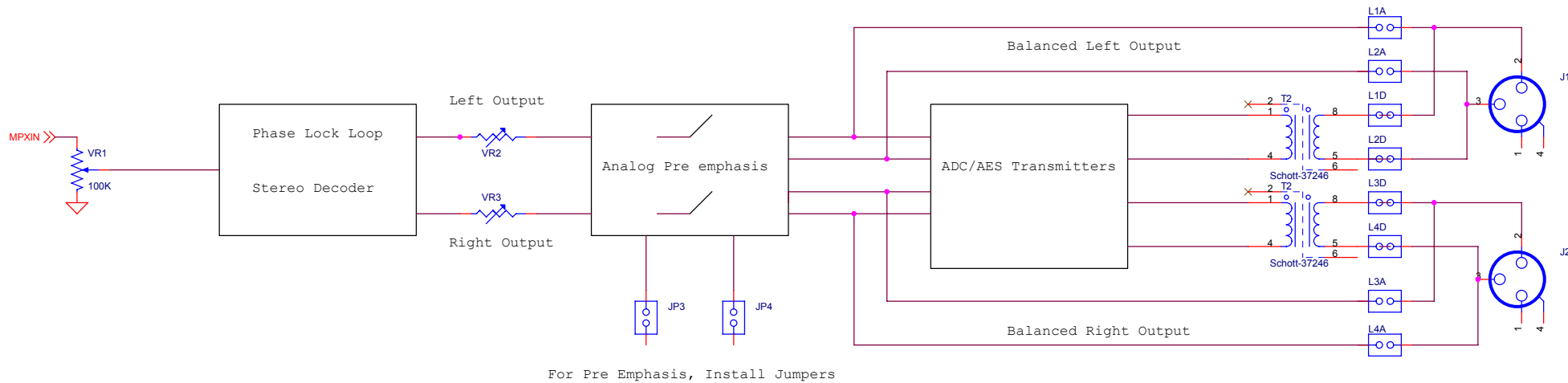

Note: Optional Balanced Left/Right Output is selectable by removing L1,2,3,4D and placing Jumpers in L1,2,3,4,A.

CTD-1 Functional Block Diagram

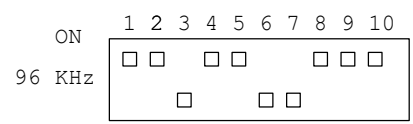
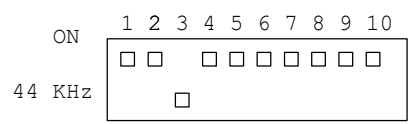
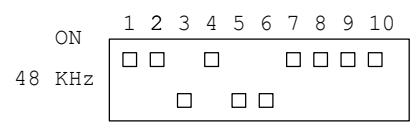
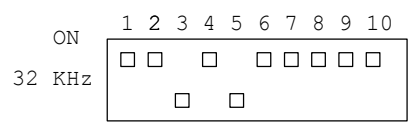
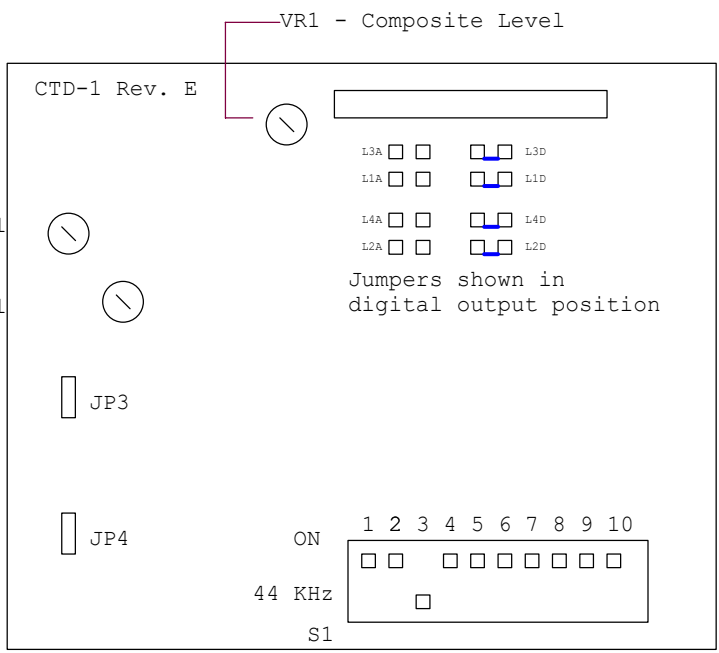

CTD-1 Set Up Diagram



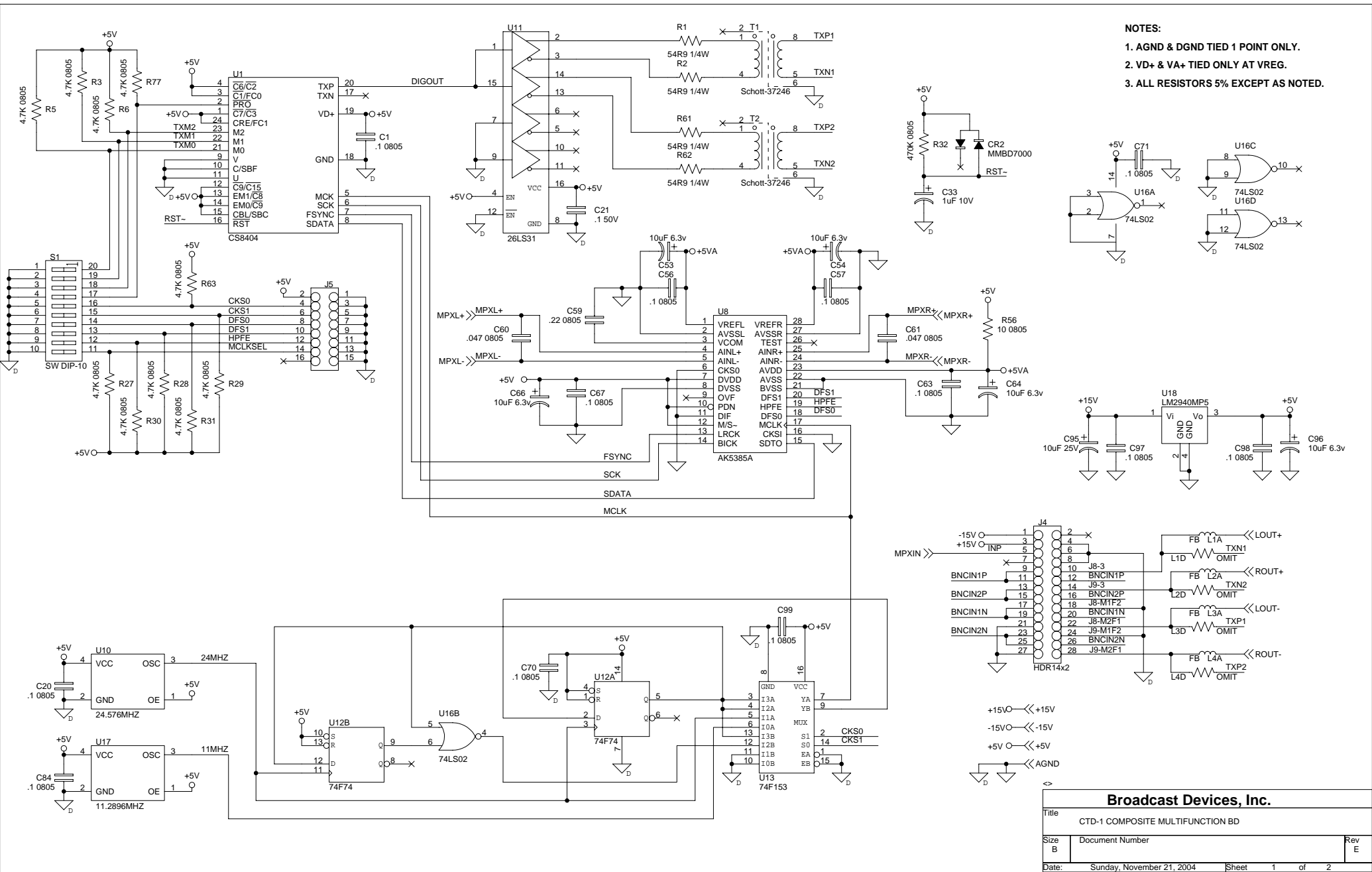

- NOTES:**
1. AGND & DGND TIED 1 POINT ONLY.
  2. VD+ & VA+ TIED ONLY AT VREG.
  3. ALL RESISTORS 5% EXCEPT AS NOTED.

<b>Broadcast Devices, Inc.</b>		
Title CTD-1 COMPOSITE MULTIFUNCTION BD		
Size B	Document Number	Rev E
Date: Sunday, November 21, 2004	Sheet 1	of 2

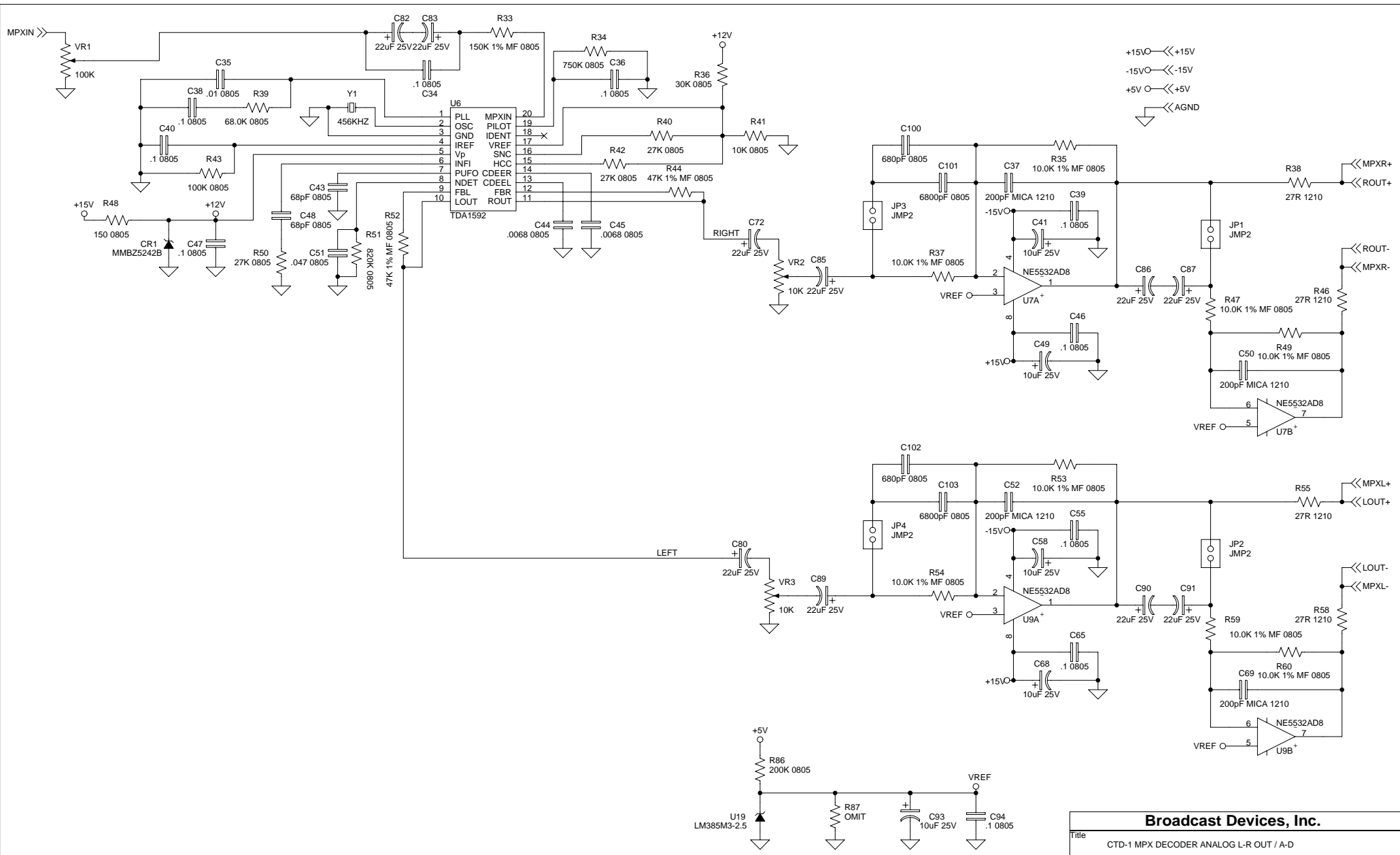

Broadcast Devices, Inc.		
Title	CTD-1 MPX DECODER ANALOG L-R OUT / A-D	
Size	Document Number	Rev E
B	<Doc>	
Date:	Sunday, November 21, 2004	Sheet 2 of 2